

**DOE Fundamentals**

**ELECTRICAL SCIENCE**  
**Module 1**  
**Basic Electrical Theory**

## TABLE OF CONTENTS

TABLE OF CONTENTS .....	i
LIST OF FIGURES.....	iv
LIST OF TABLES.....	vi
REFERENCES.....	vii
OBJECTIVES.....	viii
TERMINAL OBJECTIVE.....	viii
ENABLING OBJECTIVES .....	viii
ATOM AND ITS FORCES.....	1
The Atom.....	1
Electrostatic Force.....	2
The First Law of Electrostatics.....	3
Electrostatic Field .....	3
Potential Difference .....	5
Free Electrons .....	6
Summary .....	8
ELECTRICAL TERMINOLOGY.....	9
Conductors.....	9
Insulators.....	9
Resistors.....	9
Voltage .....	10
Current.....	10
Real and Ideal Sources .....	12
Summary .....	12
UNITS OF ELECTRICAL MEASUREMENT.....	13
System Internationale (SI) Metric System.....	13
Voltage .....	14
Current.....	14
Resistance.....	14
Ohm's Law.....	14

Conductance .....	16
Power .....	16
Inductance .....	17
Capacitance.....	17
Summary .....	18
METHODS OF PRODUCING VOLTAGE (ELECTRICITY) .....	19
Electrochemistry .....	19
Static Electricity .....	20
Magnetic Induction.....	21
Piezoelectric Effect .....	21
Thermoelectricity .....	22
Photoelectric Effect.....	23
Thermionic Emission .....	24
Summary .....	26
MAGNETISM .....	27
Magnetism.....	27
Magnetic Flux .....	29
Magnetic Flux Density .....	29
Magnetic Materials.....	29
Electromagnetism .....	30
Polarity of a Single Conductor .....	31
Magnetic Field and Polarity of a Coil .....	31
Magnetomotive Force .....	32
Field Intensity.....	33
Reluctance.....	34
Summary .....	35
MAGNETIC CIRCUITS .....	36
Magnetic Circuits .....	36
BH Magnetization Curve.....	37
Hysteresis.....	39
Magnetic Induction.....	39

Faraday's Law of Induced Voltage.....	40
Lenz's Law.....	41
Summary .....	42
ELECTRICAL SYMBOLS.....	43
Symbols.....	43
Appendix A: Metric System and Powers of Ten .....	A1
Metric System.....	A1
Metric Prefixes.....	A2
Powers of Ten.....	A3

## LIST OF FIGURES

Figure 1	The Atom .....	1
Figure 2	The Carbon Atom .....	2
Figure 3	Electrostatic Force .....	2
Figure 4	Electrostatic Field .....	3
Figure 5	Electrostatic Field Between Two Charges of Opposite Polarity .....	4
Figure 6	Electrostatic Field Between Two Charges of Like Polarity .....	4
Figure 7	Potential Difference Between Two Charged Objects .....	5
Figure 8	Energy Shells and Electron Quota .....	6
Figure 9	Electron Flow Through a Copper Wire with a Potential Difference .....	11
Figure 10	Potential Difference Across a Conductor Causes a Current to Flow .....	11
Figure 11	Voltaic Chemical Cell .....	20
Figure 12	Static Electricity .....	20
Figure 13	Generator - Electromagnetic Induction .....	21
Figure 14	Pressure Applied to Certain Crystals Produce an Electric Charge .....	22
Figure 15	Heat Energy Causes Copper to Give up Electrons to Zinc .....	23
Figure 16	Producing Electricity from Light Using a Photovoltaic Cell .....	24
Figure 17	Vacuum Tube Diode .....	25
Figure 18	Electron Spinning Around Nucleus Produces Magnetic Field .....	27
Figure 19	Magnetic Domains .....	28
Figure 20	The Law of Magnetic Attraction and Repulsion .....	28
Figure 21	The Magnetic Field Produced by Current in a Conductor .....	31
Figure 22	Left-hand Rule for Current Carrying Conductors .....	31
Figure 23	Left-hand Rule for Coils .....	32
Figure 24	Left-hand Rule to Find North Pole of an Electromagnet .....	33
Figure 25	Different Physical Forms of Electromagnets .....	35
Figure 26	Magnetic Current with Closed Iron Path .....	38
Figure 27	Typical BH Curve for Two Types of Soft Iron .....	39

Figure 28	Hysteresis Loop for Magnetic Materials .....	41
Figure 29	Induced EMF .....	42
Figure 30	Electrical Symbols .....	46

**LIST OF TABLES**

Table A-1	Base Units of the International Metric System .....	A-1
Table A-2	Supplementary SI Units .....	A-2
Table A-3	Derived SI Units .....	A-3
Table A-4	Metric Prefixes Used in Electricity .....	A-4
Table A-5	Powers of 10 .....	A-5
Table A-6	Metric Prefixes Expressed as Powers of 10 .....	A-8

## REFERENCES

- Gussow, Milton, Schaum's Outline of Basic Electricity, 2<sup>nd</sup> Edition, McGraw-Hill.
- Academic Program for Nuclear Power Plant Personnel, Volume I & II, Columbia, MD: General Physics Corporation, Library of Congress Card #A 326517, 1982.
- Sienko and Plane, Chemical Principles and Properties, 3<sup>rd</sup> Edition, McGraw-Hill.
- Nasar and Unnewehr, Electromechanics and Electric Machines, 2<sup>nd</sup> Edition, John Wiley and Sons.
- Nooger and Neville Inc., Van Valkenburgh, Basic Electricity, Vol. 5, Hayden Book Company.
- Lister, Eugene C., Electric Circuits and Machines, 7<sup>th</sup> Edition, McGraw-Hill.
- Croft, Hartwell, and Summers, American Electricians' Handbook, 16<sup>th</sup> Edition, McGraw-Hill.
- Mason, C. Russel, The Art and Science of Protective Relaying, John Wiley and Sons.
- Mileaf, Harry, Electricity One - Seven, Revised 2<sup>nd</sup> Edition, Hayden Book Company.
- Buban and Schmitt, Understanding Electricity and Electronics, 3<sup>rd</sup> Edition, McGraw-Hill.
- Kidwell, Walter, Electrical Instruments and Measurements, McGraw-Hill.



## OBJECTIVES

### TERMINAL OBJECTIVE

1.0 Given a simple electrical circuit, **APPLY** basic electrical theory fundamental principles to describe circuit operation.

### ENABLING OBJECTIVES

1.1 **DESCRIBE** the following terms:

- a. Electrostatic force
- b. Electrostatic field
- c. Potential difference
- d. Electromotive force (EMF)
- e. Ion charge

1.2 **DEFINE** the following terms:

- a. Conductor
- b. Insulator
- c. Resistor
- d. Electron current flow
- e. Conventional current flow
- f. Direct current (DC)
- g. Alternating current (AC)
- h. Ideal source
- i. Real source

1.3 **DESCRIBE** the following electrical parameters, including the unit of measurement and the relationship to other parameters.

- a. Voltage
- b. Current
- c. Resistance
- d. Conductance

- e. Power
  - f. Inductance
  - g. Capacitance
- 1.4 Given any two of the three component values of Ohm's Law, **DETERMINE** the unknown component value.
- 1.5 **DESCRIBE** how the following methods produce a voltage:
- a. Electrochemistry
  - b. Static electricity
  - c. Magnetic Induction
  - d. Piezoelectric effect
  - e. Thermoelectricity
  - f. Photoelectric effect
  - g. Thermionic emission
- 1.6 **DEFINE** the following terms:
- a. Magnetic flux
  - b. Magnetic flux density
  - c. Weber
  - d. Permeability
  - e. Magnetomotive force (mmf)
  - f. Ampere turns
  - g. Field intensity
  - h. Reluctance
- 1.7 **DESCRIBE** the following materials as they relate to permeability, including an example and an approximate relative permeability.
- a. Ferromagnetic materials
  - b. Paramagnetic materials
  - c. Diamagnetic materials
- 1.8 **EXPLAIN** the physical qualities of a simple magnetic circuit, including relationships of qualities and units of measurements.
- 1.9 Given the physical qualities of a simple magnetic circuit, **CALCULATE** the unknown values.

- 1.10 **DESCRIBE** the shape and components of a BH magnetization curve.
- 1.11 **EXPLAIN** the cause of hysteresis losses.
- 1.12 Given Faraday's Law of induced voltage:
- DESCRIBE** how varying parameters affect induced voltage.
  - CALCULATE** voltage induced in a conductor moving through a magnetic field.
- 1.13 **STATE** Lenz's Law of induction.
- 1.14 Given a standard electrical symbol, **IDENTIFY** the component that the symbol represents. The symbols will be for the following components:
- |                       |                                  |
|-----------------------|----------------------------------|
| a. Resistor           | m. Fuse                          |
| b. Capacitor          | n. Junction                      |
| c. Inductor           | o. AC voltage source             |
| d. Relay              | p. Voltmeter                     |
| e. Contacts           | q. Ammeter                       |
| f. Breaker            | r. Wattmeter                     |
| g. Switch             | s. Relay operated contacts       |
| h. Transistor         | t. Potential transformer         |
| i. Rheostat           | u. Current transformer           |
| j. Diode              | v. Wye (Y) connection            |
| k. Ground connections | w. Delta ( $\Delta$ ) connection |
| l. Vacuum tube        | x. Light bulb                    |
|                       | y. Battery                       |

## ATOM AND ITS FORCES

*What is electricity? Electricity is defined as "the flow of electrons through simple materials and devices" or "that force which moves electrons." Scientists think electricity is produced by very tiny particles called electrons and protons. These particles are too small to be seen, but exist as subatomic particles in the atom. To understand how they exist, you must first understand the structure of the atom.*

- EO 1.1      **DESCRIBE** the following terms:
- Electrostatic force
  - Electrostatic field
  - Potential difference
  - Electromotive force (EMF)
  - Ion charge

### The Atom

Elements are the basic building blocks of all matter. The atom is the smallest particle to which an element can be reduced while still keeping the properties of that element. An atom consists of a positively charged nucleus surrounded by negatively charged electrons, so that the atom as a whole is electrically neutral. The nucleus is composed of two kinds of subatomic particles, protons and neutrons, as shown in Figure 1. The proton carries a single unit positive charge equal in magnitude to the electron charge. The neutron is slightly heavier than the proton and is electrically neutral, as the name implies. These two particles exist in various combinations, depending upon the element involved. The

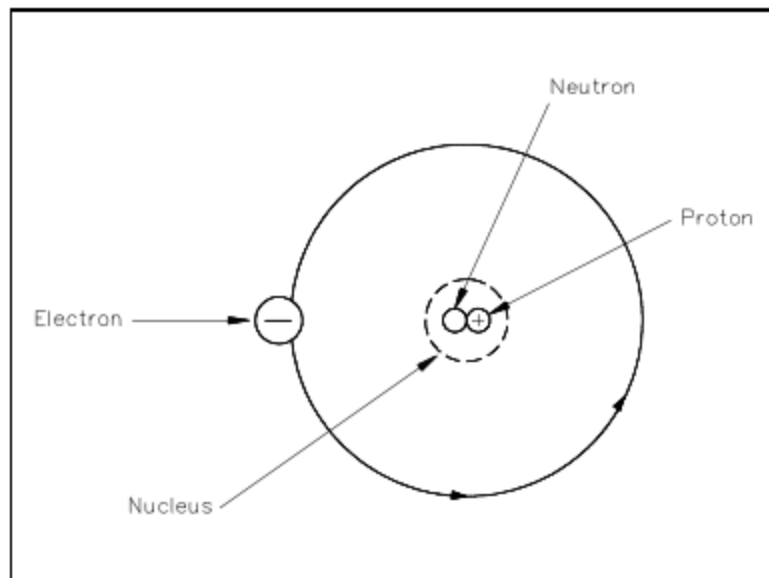

Figure 1 The Atom

electron is the fundamental negative charge (-) of electricity and revolves around the nucleus, or center, of the atom in concentric orbits, or shells.

The proton is the fundamental positive charge (+) of electricity and is located in the nucleus. The number of protons in the nucleus of any atom specifies the atomic number of that atom or of that element. For example, the carbon atom contains six protons in its nucleus; therefore, the atomic number for carbon is six, as shown in Figure 2.

In its natural state, an atom of any element contains an equal number of electrons and protons. The negative charge (-) of each electron is equal in magnitude to the positive charge (+) of each proton; therefore, the two opposite charges cancel, and the atom is said to be electrically neutral, or in balance.

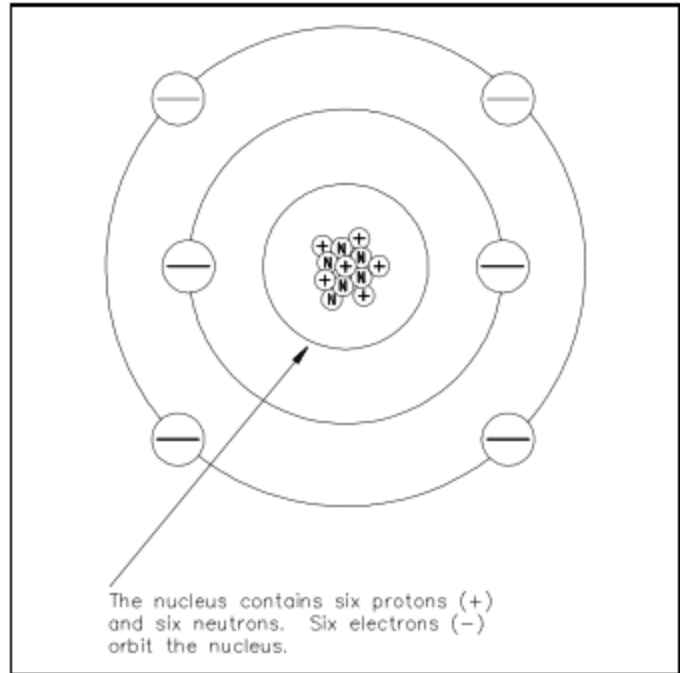

Figure 2 The Carbon Atom

### Electrostatic Force

One of the mysteries of the atom is that the electron and the nucleus attract each other. This attraction is called *electrostatic force*, the force that holds the electron in orbit. This force may be illustrated with lines as shown in Figure 3.

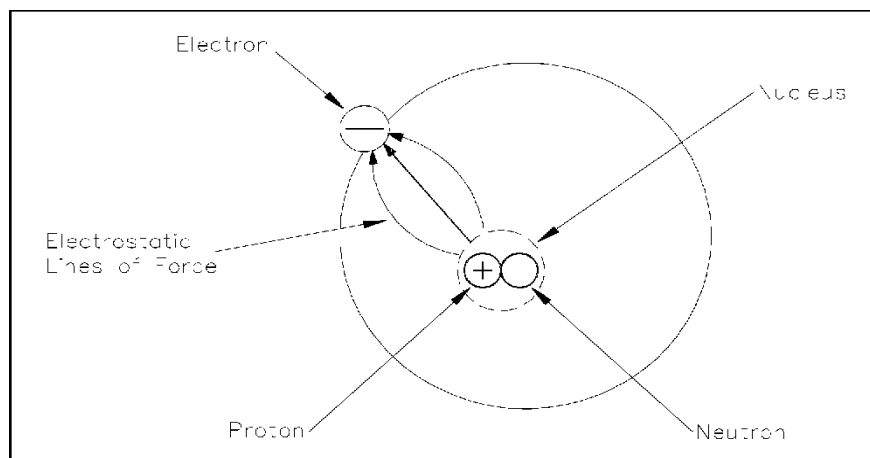

Figure 3 Electrostatic Force

Without this electrostatic force, the electron, which is traveling at high speed, could not stay in its orbit. Bodies that attract each other in this way are called charged bodies. As mentioned previously, the electron has a negative charge, and the nucleus (due to the proton) has a positive charge.

### **The First Law of Electrostatics**

The negative charge of the electron is equal, but opposite to, the positive charge of the proton. These charges are referred to as electrostatic charges. In nature, unlike charges (like electrons and protons) attract each other, and like charges repel each other. These facts are known as the *First Law of Electrostatics* and are sometimes referred to as the law of electrical charges. This law should be remembered because it is one of the vital concepts in electricity.

Some atoms can lose electrons and others can gain electrons; thus, it is possible to transfer electrons from one object to another. When this occurs, the equal distribution of negative and positive charges no longer exists. One object will contain an excess of electrons and become negatively charged, and the other will become deficient in electrons and become positively charged. These objects, which can contain billions of atoms, will then follow the same law of electrostatics as the electron and proton example shown above. The electrons that can move around within an object are said to be free electrons and will be discussed in more detail in a later section. The greater the number of these free electrons an object contains, the greater its negative electric charge. Thus, the electric charge can be used as a measure of electrons.

### **Electrostatic Field**

A special force is acting between the charged objects discussed above. Forces of this type are the result of an *electrostatic field* that exists around each charged particle or object. This electrostatic field, and the force it creates, can be illustrated with lines called "lines of force" as shown in Figure 4.

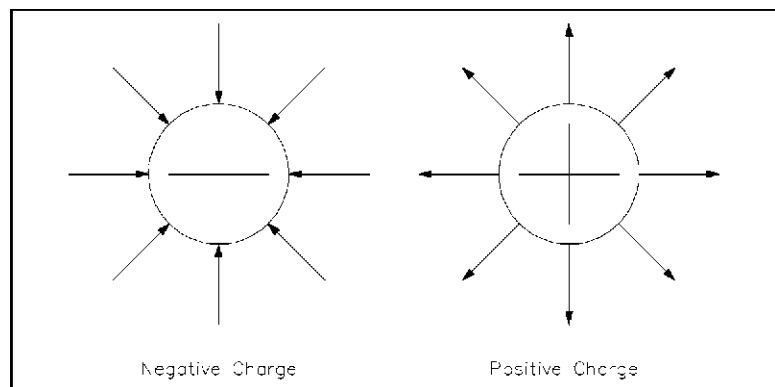

Figure 4 Electrostatic Field

Charged objects repel or attract each other because of the way these fields act together. This force is present with every charged object. When two objects of opposite charge are brought near one another, the electrostatic field is concentrated in the area between them, as shown in Figure 5. The direction of the small arrows shows the direction of the force as it would act upon an electron if it were released into the electric field.

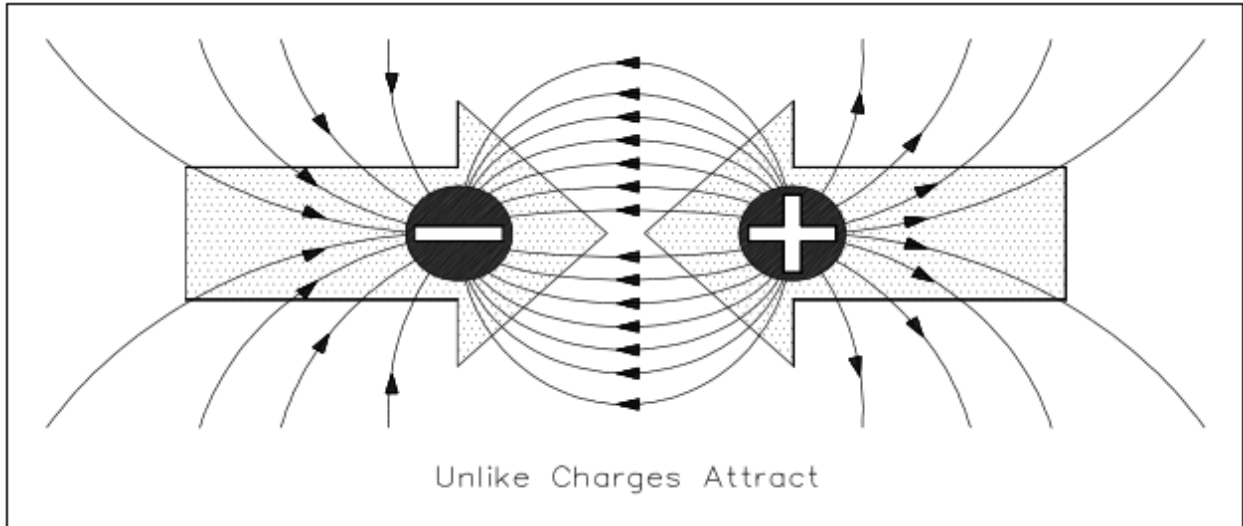

Figure 5 Electrostatic Field Between Two Charges of Opposite Polarity

When two objects of like charge are brought near one another, the lines of force repel each other, as shown in Figure 6.

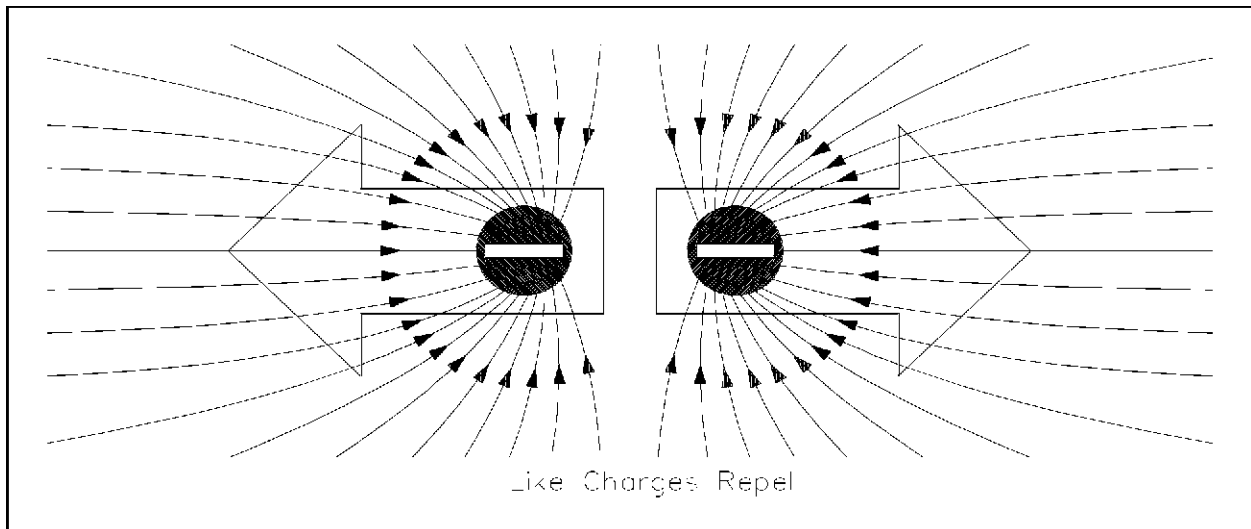

Figure 6 Electrostatic Field Between Two Charges of Like Polarity

The strength of the attraction or of the repulsion force depends upon two factors: (1) the amount of charge on each object, and (2) the distance between the objects. The greater the charge on the objects, the greater the electrostatic field. The greater the distance

between the objects, the weaker the electrostatic field between them, and vice versa. This leads us to the law of electrostatic attraction, commonly referred to as Coulomb's Law of electrostatic charges, which states that the force of electrostatic attraction, or repulsion, is directly proportional to the product of the two charges and inversely proportional to the square of the distance between them as shown in Equation 1-1.

$$F = k \frac{q_1 \times q_2}{d^2} \quad (1-1)$$

where

F = force of electrostatic attraction or repulsion (Newtons)

k = constant of proportionality (N-m<sup>2</sup>/Coulomb<sup>2</sup>)

q<sub>1</sub> = charge of first particle (Coulombs)

q<sub>2</sub> = charge of second particle (Coulombs)

d = distance between two particles (Meters)

If q<sub>1</sub> and q<sub>2</sub> are both either positively or negatively charged, the force is repulsive. If q<sub>1</sub> and q<sub>2</sub> are opposite polarity or charge, the force is attractive.

### **Potential Difference**

*Potential difference* is the term used to describe how large the electrostatic force is between two charged objects. If a charged body is placed between two objects

with a potential difference, the charged body will try to move in one direction, depending upon the polarity of the object. If an electron is placed between a negatively-charged body and a positively-charged body, the action due to the potential difference is to push the electron toward the positively-charged object. The electron, being negatively charged, will be repelled from the negatively-charged object and attracted by the positively-charged object, as shown in Figure 7.

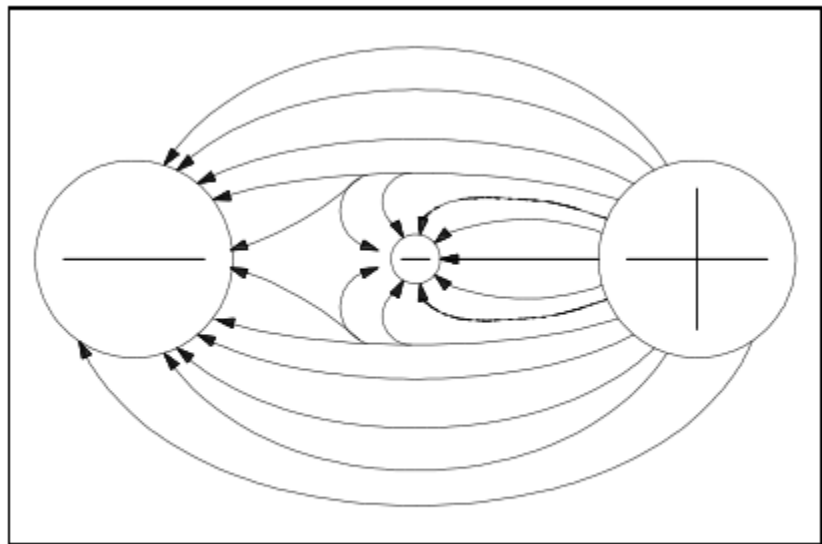

Figure 7 Potential Difference Between Two Charged Objects



Due to the force of its electrostatic field, these electrical charges have the ability to do work by moving another charged particle by attraction and/or repulsion. This ability to do work is called "potential"; therefore, if one charge is different from another, there is a potential difference between them. The sum of the potential differences of all charged particles in the electrostatic field is referred to as *electromotive force* (EMF).

The basic unit of measure of potential difference is the "volt." The symbol for potential difference is "V," indicating the ability to do the work of forcing electrons to move. Because the volt unit is used, potential difference is also called "voltage." The unit volt will be covered in greater detail in the next chapter.

### Free Electrons

Electrons are in rapid motion around the nucleus. While the electrostatic force is trying to pull the nucleus and the electron together, the electron is in motion and trying to pull away. These two effects balance, keeping the electron in orbit. The electrons in an atom exist in different energy levels. The energy level of an electron is proportional to its distance from the nucleus. Higher energy level electrons exist in orbits, or shells, that are farther away from the nucleus. These shells nest inside one another and surround the nucleus. The nucleus is the center of all the shells. The shells are lettered beginning with the shell nearest the nucleus: K, L, M, N, O, P, and Q. Each shell has a maximum number of electrons it can hold. For example, the K shell will hold a maximum of two electrons and the L shell will hold a maximum of eight electrons. As shown in Figure 8, each shell has a specific number of electrons that it will hold for a particular atom.

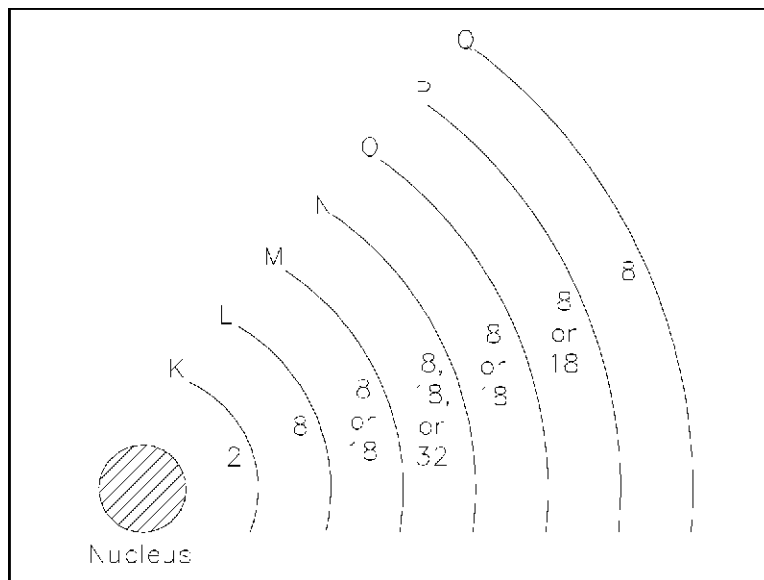

Figure 8 Energy Shells and Electron Quota

There are two simple rules concerning electron shells that make it possible to predict the electron distribution of any element:

1. The maximum number of electrons that can fit in the outermost shell of any atom is eight.
2. The maximum number of electrons that can fit in the next-to-outermost shell of any atom is 18.

An important point to remember is that when the outer shell of an atom contains eight electrons, the atom becomes very stable, or very resistant to changes in its structure. This also means that atoms with one or two electrons in their outer shell can lose electrons much more easily than atoms with full outer shells. The electrons in the outermost shell are called *valence electrons*. When external energy, such as heat, light, or electrical energy, is applied to certain materials, the electrons gain energy, become excited, and may move to a higher energy level. If enough energy is applied to the atom, some of the valence electrons will leave the atom. These electrons are called *free electrons*. It is the movement of free electrons that provides electric current in a metal conductor. An atom that has lost or gained one or more electrons is said to be *ionized* or to have an *ion change*. If the atom loses one or more electrons, it becomes positively charged and is referred to as a *positive ion*. If an atom gains one or more electrons, it becomes negatively charged and is referred to as a *negative ion*.

## **Summary**

The important information contained in this chapter is summarized below.

### **Forces Around Atoms Summary**

- Electrostatic Force - force that holds an electron in orbit around a nucleus
- Electrostatic Field - force acting between charged objects that causes them to repel or attract
- Potential Difference - measures how large the electrostatic force is between two charged objects. According to Coulomb's Law, charged bodies attract or repel each other with a force that is directly proportional to the product of their charges and is inversely proportional to the square of the distance between them.
- Electromotive Force (EMF) - sum of the potential differences of all charged particles in an electrostatic field
- Ion Charge - dependent on the loss or gain of free electrons (if an atom gains an electron - negative ion charge; if an atom loses an electron positive ion charge)

## ELECTRICAL TERMINOLOGY

*Knowledge of key electrical terminology is necessary to fully understand principles in electrical science.*

EO 1.2      **DEFINE** the following terms:

- a. Conductor
- b. Insulator
- c. Resistor
- d. Electron current flow
- e. Conventional current flow
- f. Direct current (DC)
- g. Alternating current (AC)
- h. Ideal source
- i. Real source

### **Conductors**

*Conductors* are materials with electrons that are loosely bound to their atoms, or materials that permit free motion of a large number of electrons. Atoms with only one valence electron, such as copper, silver, and gold, are examples of good conductors. Most metals are good conductors.

### **Insulators**

*Insulators*, or nonconductors, are materials with electrons that are tightly bound to their atoms and require large amounts of energy to free them from the influence of the nucleus. The atoms of good insulators have their valence shells filled with eight electrons, which means they are more than half filled. Any energy applied to such an atom will be distributed among a relatively large number of electrons. Examples of insulators are rubber, plastics, glass, and dry wood.

### **Resistors**

*Resistors* are made of materials that conduct electricity, but offer opposition to current flow. These types of materials are also called *semiconductors* because they are neither good conductors nor good insulators. Semiconductors have more than one or two

electrons in their valence shells, but less than seven or eight. Examples of semiconductors are carbon, silicon, germanium, tin, and lead. Each has four valence electrons.

### **Voltage**

The basic unit of measure for potential difference is the *volt* (symbol V), and, because the volt unit is used, potential difference is called *voltage*. An object's electrical charge is determined by the number of electrons that the object has gained or lost. Because such a large number of electrons move, a unit called the "coulomb" is used to indicate the charge. One coulomb is equal to  $6.28 \times 10^{18}$  (billion, billion) electrons. For example, if an object gains one coulomb of negative charge, it has gained 6,280,000,000,000,000,000 extra electrons. A volt is defined as a difference of potential causing one coulomb of current to do one joule of work. A volt is also defined as that amount of force required to force one ampere of current through one ohm of resistance. The latter is the definition with which we will be most concerned in this module.

### **Current**

The density of the atoms in copper wire is such that the valence orbits of the individual atoms overlap, causing the electrons to move easily from one atom to the next. Free electrons can drift from one orbit to another in a random direction. When a potential difference is applied, the direction of their movement is controlled. The strength of the potential difference applied at each end of the wire determines how many electrons change from a random motion to a more directional path through the wire. The movement or flow of these electrons is called *electron current flow* or just *current*.

To produce current, the electrons must be moved by a potential difference. The symbol for current is (I). The basic measurement for current is the ampere (A). One ampere of current is defined as the movement of one coulomb of charge past any given point of a conductor during one second of time.

If a copper wire is placed between two charged objects that have a potential difference, all of the negatively-charged free electrons will feel a force pushing them from the negative charge to the positive charge. This force opposite to the conventional direction of the electrostatic lines of force is shown in Figure 9.

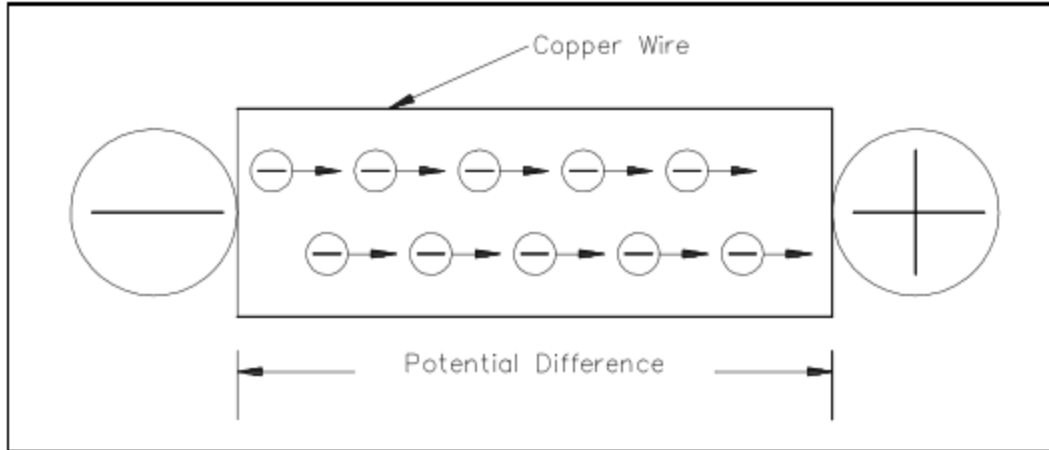

Figure 9 Electron Flow Through a Copper Wire with a Potential Difference

The direction of electron flow, shown in Figure 10, is from the negative (-) side of the battery, through the wire, and back to the positive (+) side of the battery. The direction of electron flow is from a point of negative potential to a point of positive potential. The solid arrow shown in Figure 10 indicates the direction of electron flow. As electrons vacate their atoms during electron current flow, positively charged atoms (holes) result. The flow of electrons in one direction causes a flow of positive charges. The direction of the positive charges is in the opposite direction of the electron flow. This flow of positive charges is known as *conventional current* and is shown in Figure 10 as a dashed arrow. All of the electrical effects of electron flow from negative to positive, or from a higher potential to a lower potential, are the same as those that would be created by a flow of positive charges in the opposite direction. Therefore, it is important to realize that both conventions are in use and that they are essentially equivalent; that is, all effects predicted are the same. In this text, we will be using electron flow in our discussions.

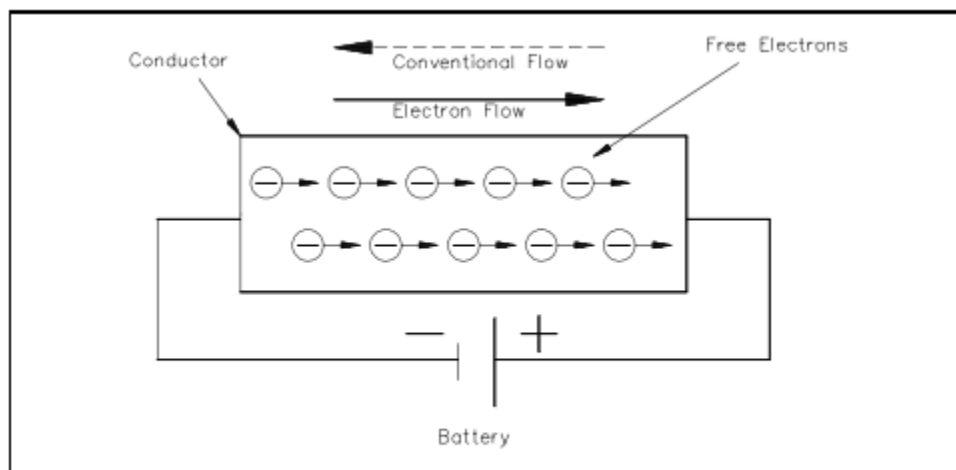

Figure 10 Potential Difference Across a Conductor Causes a Current to Flow

Generally, electric current flow can be classified as one of two general types: *Direct Current* (DC) or *Alternating Current* (AC). A direct current flows continuously in the same direction. An alternating current periodically reverses direction. We will be studying DC and AC current in more detail later in this text. An example of DC current is that current obtained from a battery. An example of AC current is common household current.

### **Real and Ideal Sources**

An *ideal source* is a theoretical concept of an electric current or voltage supply (such as a battery) that has no losses and is a perfect voltage or current supply. Ideal sources are used for analytical purposes only since they cannot occur in nature.

A *real source* is a real life current or voltage supply that has some losses associated with it.

### **Summary**

The important information contained in this chapter is summarized below.

#### **Terminology Summary**

- Conductor - material with electrons loosely bound to its atoms or that permits free motion of large number of electrons
- Insulator - material with electrons tightly bound to its atoms; requires large amounts of energy to free electrons from its nuclei
- Resistor - material that conducts electricity, but opposes current flow
- Electron Current Flow - current flow from negative to positive potentials
- Conventional Current Flow - current flow from positive to negative potentials
- Direct Current - current flow continuously in the same direction
- Alternating Current - current flow periodically reverses direction
- Ideal Source - theoretical current or voltage supply with no losses
- Real Source - actual current or voltage supply with losses

## UNITS OF ELECTRICAL MEASUREMENT

*Using Ohm's Law and the System Internationale (SI) Metric System, electrical measuring units can be derived.*

- EO 1.3     **DESCRIBE** the following electrical parameters, including the unit of measurement and the relationship to other parameters.
- a. Voltage
  - b. Current
  - c. Resistance
  - d. Conductance
  - e. Power
  - f. Inductance
  - g. Capacitance
- EO 1.4     Given any two of the three component values of Ohm's Law, **DETERMINE** the unknown component value.

### **System Internationale (SI) Metric System**

Electrical units of measurement are based on the International (metric) System, also known as the SI System. Units of electrical measurement include the following:

- Ampere
- Volt
- Ohm
- Siemens
- Watt
- Henry
- Farad

Appendix A provides more information concerning the metric system, metric prefixes, and powers of 10 that are used in electrical measuring units.



## **Voltage**

*Voltage*, electromotive force (emf), or potential difference, is described as the pressure or force that causes electrons to move in a conductor. In electrical formulas and equations, you will see voltage symbolized with a capital E, while on laboratory equipment or schematic diagrams, the voltage is often represented with a capital V.

## **Current**

Electron *current*, or amperage, is described as the movement of free electrons through a conductor. In electrical formulas, current is symbolized with a capital I, while in the laboratory or on schematic diagrams, it is common to use a capital A to indicate amps or amperage (amps).

## **Resistance**

Now that we have discussed the concepts of voltage and current, we are ready to discuss a third key concept called resistance. *Resistance* is defined as the opposition to current flow. The amount of opposition to current flow produced by a material depends upon the amount of available free electrons it contains and the types of obstacles the electrons encounter as they attempt to move through the material. Resistance is measured in ohms and is represented by the symbol (R) in equations. One ohm is defined as that amount of resistance that will limit the current in a conductor to one ampere when the potential difference (voltage) applied to the conductor is one volt. The shorthand notation for ohm is the Greek letter capital omega ( $\Omega$ ). If a voltage is applied to a conductor, current flows. The amount of current flow depends upon the resistance of the conductor. The lower the resistance, the higher the current flow for a given amount of voltage. The higher the resistance, the lower the current flow.

## **Ohm's Law**

In 1827, George Simon Ohm discovered that there was a definite relationship between voltage, current, and resistance in an electrical circuit. Ohm's Law defines this relationship and can be stated in three ways.

1. Applied voltage equals circuit current times the circuit resistance. Equation (1-2) is a mathematical representation of this concept.

$$E = I \times R \quad \text{or} \quad E = I R \quad (1-2)$$

2. Current is equal to the applied voltage divided by the circuit resistance. Equation (1-3) is a mathematical representation of this concept.

$$I = E / R \quad (1-3)$$

3. Resistance of a circuit is equal to the applied voltage divided by the circuit current. Equation (1-4) is a mathematical representation of this concept.

$$R \text{ (or } \Omega = E / I \quad (1-4)$$

where:

I = current (A)

E = voltage (V)

R = resistance ( $\Omega$ )

If any two of the component values are known, the third can be calculated.

Example 1: Given that I = 2 A, E = 12 V, find the circuit resistance.

Solution:

Since applied voltage and circuit current are known, use Ohm's Law to solve for resistance.

$$R = E / I$$

$$R = 12V / 2A = 6\Omega$$

Example 2: Given E = 260 V and R = 240  $\Omega$ , what current will flow through a circuit?

Solution:

Since applied voltage and resistance are known, use Ohm's Law to solve for current.

$$I = E / R$$

$$I = 260V / 240\Omega = 1.08A$$

Example 3: Find the applied voltage, when given circuit resistance of 100  $\Omega$  and circuit current of 0.5 amps.

Solution:

Since circuit resistance and circuit current are known, use Ohm's Law to solve for applied voltage.

$$E = I R$$

$$E = 0.5A \times 100\Omega = 50V$$

## Conductance

The word "reciprocal" is sometimes used to mean "the opposite of." The opposite, or reciprocal, of resistance is called *conductance*. As described above, resistance is the opposition to current flow. Since resistance and conductance are opposites, conductance can be defined as the ability to conduct current. For example, if a wire has a high conductance, it will have low resistance, and vice-versa. Conductance is found by taking the reciprocal of the resistance. The unit used to specify conductance is called "mho," which is ohm spelled backwards. The symbol for "mho" is the Greek letter omega inverted ( $\text{̍}$ ). The symbol for conductance when used in a formula is G. Equation (1-5) is the mathematical representation of conductance obtained by relating the definition of conductance ( $1/R$ ) to Ohm's Law, Equation (1-4).

$$G = 1 / \text{RESISTANCE} = I / E \quad (1-5)$$

Example: If a resistor (R) has five ohms, what will its conductance (G) be in mhos?

Solution:

$$G \text{ (or } \text{̍}) = 1 / R = 1 / 5 = 0.2\text{̍}$$

## Power

Electricity is generally used to do some sort of work, such as turning a motor or generating heat. Specifically, *power* is the rate at which work is done, or the rate at which heat is generated. The unit commonly used to specify electric power is the watt. In equations, you will find power abbreviated with the capital letter P, and watts, the units of measure for power, are abbreviated with the capital letter W. Power is also described as the current (I) in a circuit times the voltage (E) across the circuit. Equation (1-6) is a mathematical representation of this concept.

$$P = I \times E \quad \text{or} \quad P = I E \quad (1-6)$$

Using Ohm's Law for the value of voltage (E),

$$E = I \times R$$

and using substitution laws,

$$P = I \times (I \times R)$$

Power can be described as the current (I) in a circuit squared times the resistance (R) of the circuit. Equation (1-7) is the mathematical representation of this concept.

$$P = I^2 R \quad (1-7)$$

## **Inductance**

*Inductance* is defined as the ability of a coil to store energy, induce a voltage in itself, and oppose changes in current flowing through it. The symbol used to indicate inductance in electrical formulas and equations is a capital L. The units of measurement are called henries. The unit henry is abbreviated by using the capital letter H. One henry is the amount of inductance (L) that permits one volt to be induced ( $V_L$ ) when the current through the coil changes at a rate of one ampere per second. Equation (1-8) is the mathematical representation of the rate of change in current through a coil per unit time.

$$\Delta I / \Delta t \quad (1-8)$$

Equation (1-9) is the mathematical representation for the voltage  $V_L$  induced in a coil with inductance L. The negative sign indicates that voltage induced opposes the change in current through the coil per unit time ( $\Delta I / \Delta t$ ).

$$V_L = -L \Delta I / \Delta t \quad (1-9)$$

Inductance will be studied in further detail later in this text.

## **Capacitance**

*Capacitance* is defined as the ability to store an electric charge and is symbolized by the capital letter C. Capacitance (C), measured in farads, is equal to the amount of charge (Q) that can be stored in a device or capacitor divided by the voltage (E) applied across the device or capacitor plates when the charge was stored. Equation (1-10) is the mathematical representation for capacitance.

$$C = Q / E \quad (1-10)$$

**Summary**

The important information contained in this chapter is summarized below.

**Electrical Units Summary**

<u>Parameter</u>	<u>Measuring Unit</u>	<u>Relationship</u>
Voltage	volt (V or E)	$E = I \times R$
Current	amp (I)	$I = E / R$
Resistance	ohm (R or $\Omega$ )	$R = E / I$
Conductance	mho (G or $\bar{O}$ )	$G = 1 / R$ or $I / E$
Power	watt (W)	$P = I E$ or $P = I^2 R$
Inductance	henry (L or H)	$V_L = -L (\Delta I / \Delta t)$
Capacitance	farad (C)	$C = Q / E$ (Q is charge)

## METHODS OF PRODUCING VOLTAGE (ELECTRICITY)

*This section provides information on the following methods of producing electricity:*

- *Electrochemistry*
- *Static (friction)*
- *Induction (magnetism)*
- *Piezoelectric (pressure)*
- *Thermal (heat)*
- *Light*
- *Thermionic emission*

EO 1.5     **DESCRIBE** how the following methods produce a voltage:

- a. Electrochemistry
- b. Static electricity
- c. Magnetic induction
- d. Piezoelectric effect
- e. Thermoelectricity
- f. Photoelectric effect
- g. Thermionic emission

### **Electrochemistry**

Chemicals can be combined with certain metals to cause a chemical reaction that will transfer electrons to produce electrical energy. This process works on the *electrochemistry* principle. One example of this principle is the voltaic chemical cell, shown in Figure 11. A chemical reaction produces and maintains opposite charges on two dissimilar metals that serve as the positive and negative terminals. The metals are in contact with an electrolyte solution. Connecting together more than one of these cells will produce a battery.

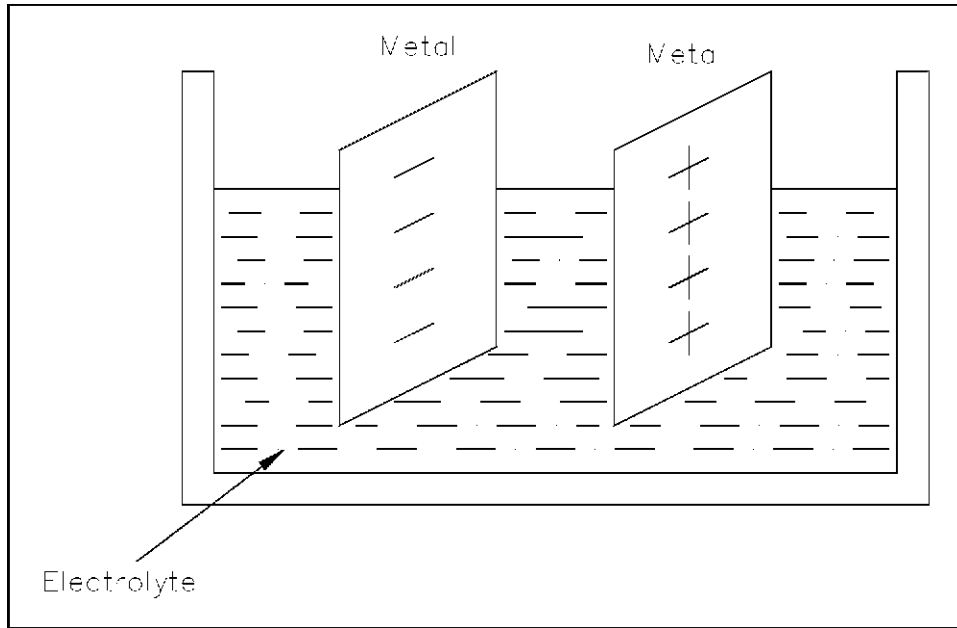

Figure 11 Voltaic Chemical Cell

Example: A battery can maintain a potential difference between its positive and negative terminals by chemical action. Various types of cells and batteries will be studied in more detail in Module 4, Batteries.

### **Static Electricity**

Atoms with the proper number of electrons in orbit around them are in a neutral state, or have a "zero charge." A body of matter consisting of these atoms will neither attract nor repel other matter that is in its vicinity. If electrons are removed from the atoms in this body of matter, as happens due to friction when one rubs a glass rod with a silk cloth, it will become electrically positive as shown in Figure 12. If this body of matter (e.g., glass rod) comes near, but not in contact with, another body having a normal charge, an electric force is exerted between them because of their unequal charges. The existence of this force is referred to as *static electricity* or *electrostatic force*.

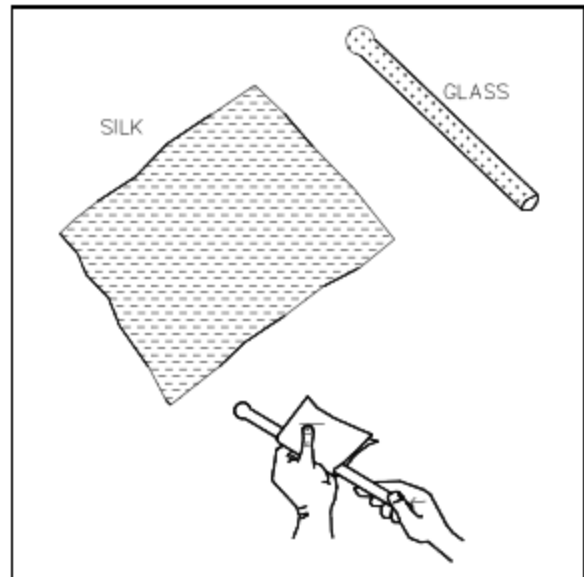

Figure 12 Static Electricity

**Example:** Have you ever walked across a carpet and received a shock when you touched a metal door knob? Your shoe soles built up a charge by rubbing on the carpet, and this charge was transferred to your body. Your body became positively charged and, when you touched the zero-charged door knob, electrons were transferred to your body until both you and the door knob had equal charges.

### **Magnetic Induction**

A generator is a machine that converts mechanical energy into electrical energy by using the principle of *magnetic induction*. Magnetic induction is used to produce a voltage by rotating coils of wire through a stationary magnetic field, as shown in Figure 13, or by rotating a magnetic field through stationary coils of wire. This is one of the most useful and widely-employed applications of producing vast quantities of electric power. Magnetic induction will be studied in more detail in the next two chapters "Magnetism," and "Magnetic Circuits."

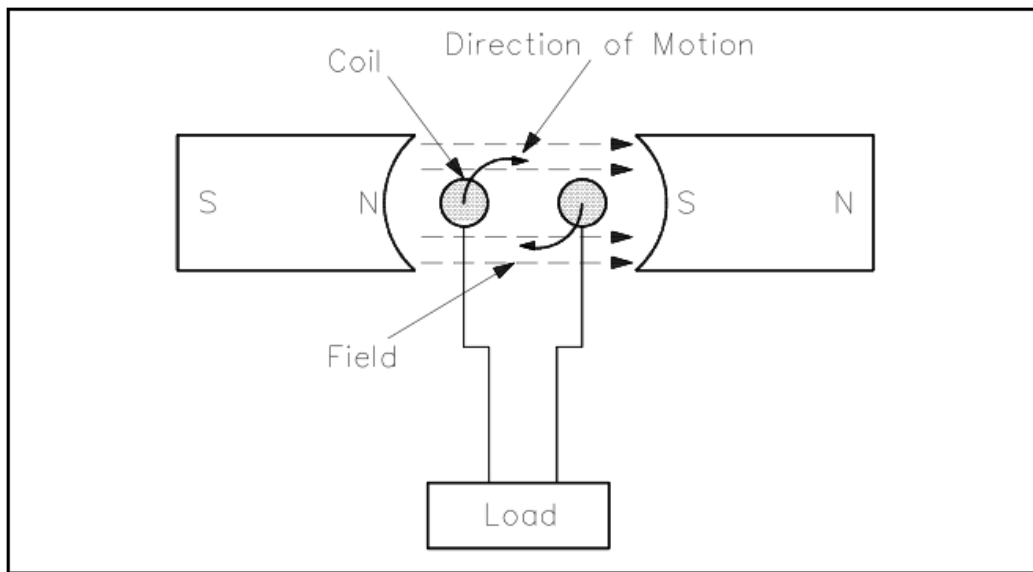

Figure 13 Generator - Electromagnetic Induction

### **Piezoelectric Effect**

By applying pressure to certain crystals (such as quartz or Rochelle salts) or certain ceramics (like barium titanate), electrons can be driven out of orbit in the direction of the force. Electrons leave one side of the material and accumulate on the other side, building up positive and negative charges on opposite sides, as shown in Figure 14. When the pressure is released, the electrons return to their orbits. Some materials will react to bending pressure, while others will respond to twisting pressure. This



generation of voltage is known as the *piezoelectric effect*. If external wires are connected while pressure and voltage are present, electrons will flow and current will be produced. If the pressure is held constant, the current will flow until the potential difference is equalized.

When the force is removed, the material is decompressed and immediately causes an electric force in the opposite direction. The power capacity of these materials is extremely small. However, these materials are very useful because of their extreme sensitivity to changes of mechanical force.

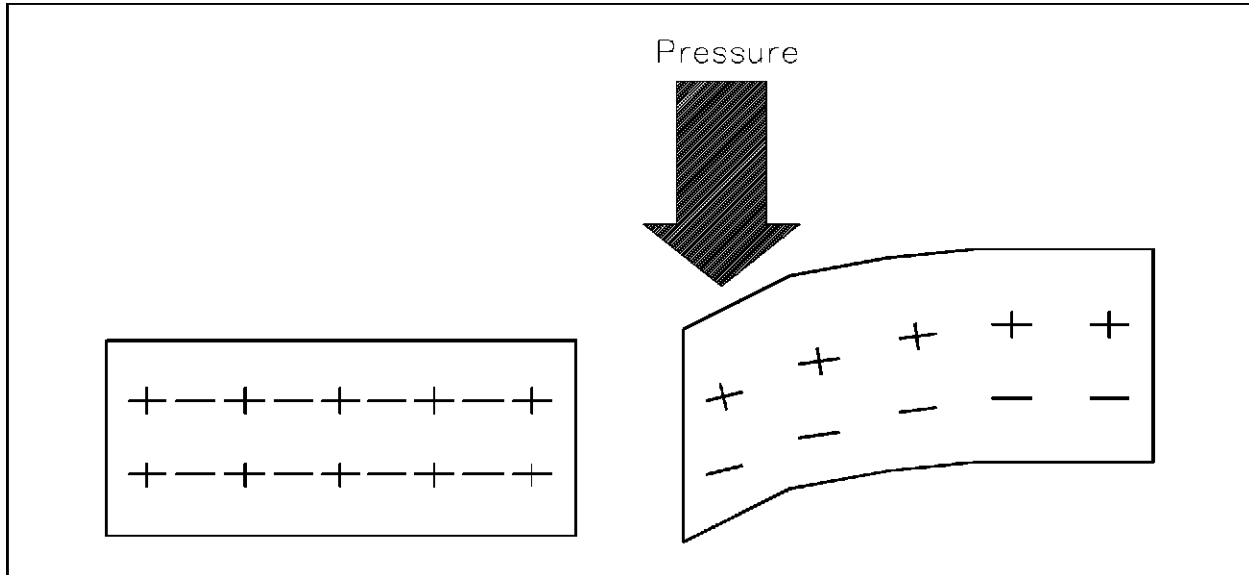

Figure 14 Pressure Applied to Certain Crystals Produces an Electric Charge

**Example:** One example is the crystal phonograph cartridge that contains a Rochelle salt crystal. A phonograph needle is attached to the crystal. As the needle moves in the grooves of a record, it swings from side to side, applying compression and decompression to the crystal. This mechanical motion applied to the crystal generates a voltage signal that is used to reproduce sound.

### **Thermoelectricity**

Some materials readily give up their electrons and others readily accept electrons. For example, when two dissimilar metals like copper and zinc are joined together, a transfer of electrons can take place. Electrons will leave the copper atoms and enter the zinc atoms. The zinc gets a surplus of electrons and becomes negatively charged. The copper loses electrons and takes on a positive charge. This creates a voltage potential across the junction of the two metals. The heat energy of normal room temperature is enough to make them release and gain electrons, causing a measurable voltage

potential. As more heat energy is applied to the junction, more electrons are released, and the voltage potential becomes greater, as shown in Figure 15. When heat is removed and the junction cools, the charges will dissipate and the voltage potential will decrease. This process is called *thermoelectricity*. A device like this is generally referred to as a "thermocouple."

The thermoelectric voltage in a thermocouple is dependent upon the heat energy applied to the junction of the two dissimilar metals. Thermocouples are widely used to measure temperature and as heat-sensing devices in automatic temperature controlled equipment.

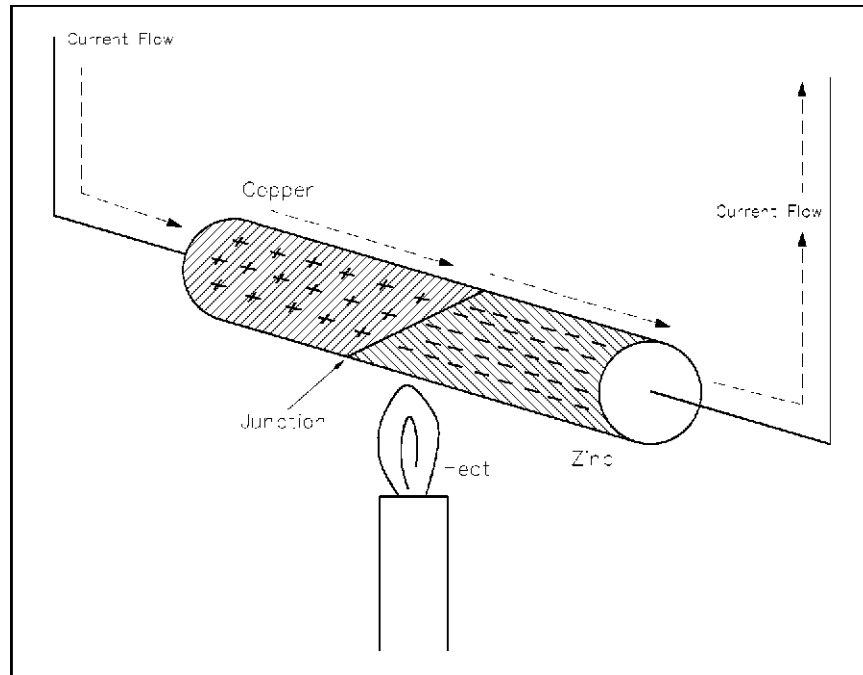

Figure 15 Heat Energy Causes Copper to Give up Electrons to Zinc

Thermocouple power capacities are very small compared to some other sources, but are somewhat greater than those of crystals.

Generally speaking, a thermocouple can be subjected to higher temperatures than ordinary mercury or alcohol thermometers.

### **Photoelectric Effect**

Light is a form of energy and is considered by many scientists to consist of small particles of energy called photons. When the photons in a light beam strike the surface of a material, they release their energy and transfer it to the atomic electrons of the material. This energy transfer may dislodge electrons from their orbits around the surface of the substance. Upon losing electrons, the photosensitive (light sensitive)

material becomes positively charged and an electric force is created, as shown in Figure 16.

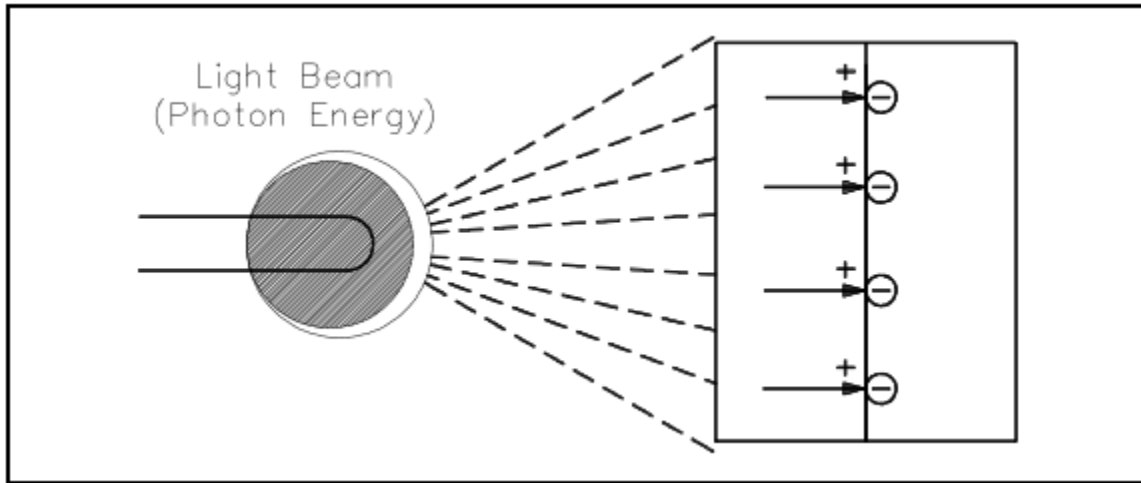

Figure 16 Producing Electricity from Light Using a Photovoltaic Cell

This phenomenon is called the *photoelectric effect* and has wide applications in electronics, such as photoelectric cells, photovoltaic cells, optical couplers, and television camera tubes. Three uses of the photoelectric effect are described below.

- Photovoltaic: The light energy in one of two plates that are joined together causes one plate to release electrons to the other. The plates build up opposite charges, like a battery (Figure 16).
- Photoemission: The photon energy from a beam of light could cause a surface to release electrons in a vacuum tube. A plate would then collect the electrons.
- Photoconduction: The light energy applied to some materials that are normally poor conductors causes free electrons to be produced in the materials so that they become better conductors.

### **Thermionic Emission**

A thermionic energy converter is a device consisting of two electrodes placed near one another in a vacuum. One electrode is normally called the cathode, or emitter, and the other is called the anode, or plate. Ordinarily, electrons in the cathode are prevented from escaping from the surface by a potential-energy barrier. When an electron starts to move away from the surface, it induces a corresponding positive charge in the material, which tends to pull it back into the surface. To escape, the electron must somehow acquire enough energy to overcome this energy barrier. At ordinary temperatures, almost none of the electrons can acquire enough energy to escape. However, when the cathode is very hot, the electron energies are greatly increased by thermal motion. At

sufficiently high temperatures, a considerable number of electrons are able to escape. The liberation of electrons from a hot surface is called *thermionic emission*.

The electrons that have escaped from the hot cathode form a cloud of negative charges near it called a space charge. If the plate is maintained positive with respect to the cathode by a battery, the electrons in the cloud are attracted to it. As long as the potential difference between the electrodes is maintained, there will be a steady current flow from the cathode to the plate.

The simplest example of a thermionic device is a vacuum tube diode in which the only electrodes are the cathode and plate, or anode, as shown in Figure 17. The diode can be used to convert alternating current (AC) flow to a pulsating direct current (DC) flow.

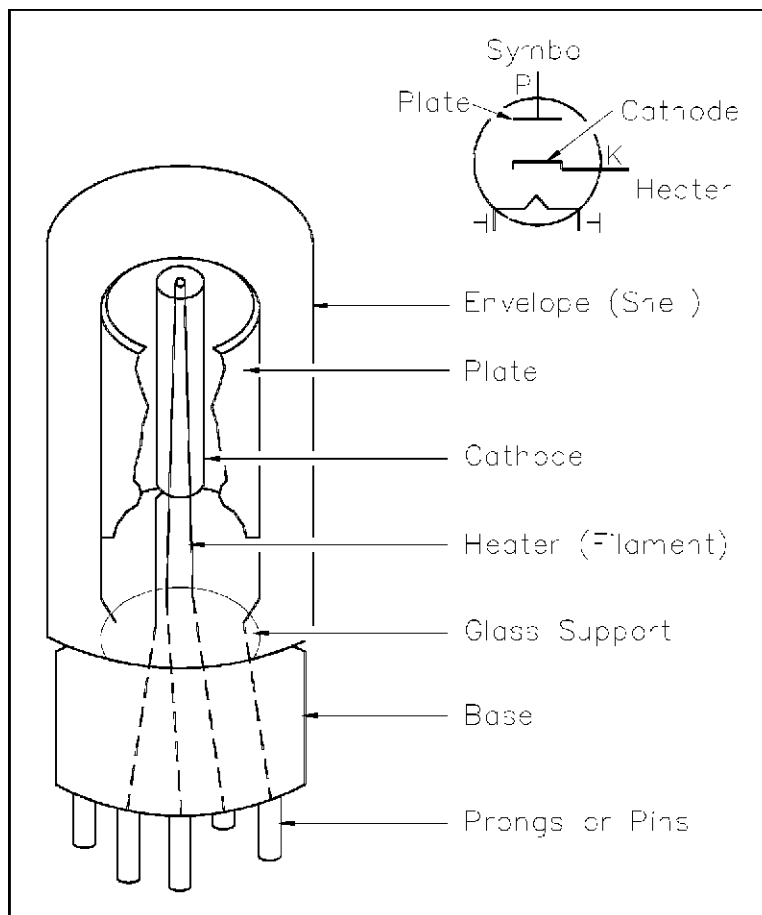

Figure 17 Vacuum Tube Diode

## **Summary**

The important information contained in this chapter is summarized below.

### **Methods of Producing Electricity Summary**

- Electrochemistry - Combining chemicals with certain metals causes a chemical reaction that transfers electrons.
- Static electricity - When an object with a normally neutral charge loses electrons, due to friction, and comes in contact with another object having a normal charge, an electric charge is exerted between the two objects.
- Magnetic induction - Rotating coils of wire through a stationary magnetic field or by rotating a magnetic field through a stationary coil of wire produces a potential.
- Piezoelectric effect - Bending or twisting certain materials will cause electrons to drive out of orbit in the direction of the force. When the force is released, the electrons return to their original orbit.
- Thermoelectricity - Heating two joined dissimilar materials will cause a transfer of electrons between the materials setting up a current flow.
- Photoelectric effect - Dislodging of electrons from their orbits by light beams creates positively-charged objects.
- Thermionic emission - Freeing electrons from a hot surface causes electrons to escape.

## MAGNETISM

*Certain metals and metallic oxides have the ability to attract other metals. This property is called magnetism, and the materials which have this property are called magnets. Some magnets are found naturally while others must be manufactured.*

EO 1.6 **DEFINE** the following terms:

- a. Magnetic flux
- b. Magnetic flux density
- c. Weber
- d. Permeability
- e. Magnetomotive force (mmf)
- f. Ampere turns
- g. Field intensity
- h. Reluctance

EO 1.7 **DESCRIBE** the following materials as they relate to permeability, including an example and an approximate relative permeability.

- a. Ferromagnetic materials
- b. Paramagnetic materials
- c. Diamagnetic materials

### Magnetism

Magnetism is a result of electrons spinning on their own axis around the nucleus (Figure 18).

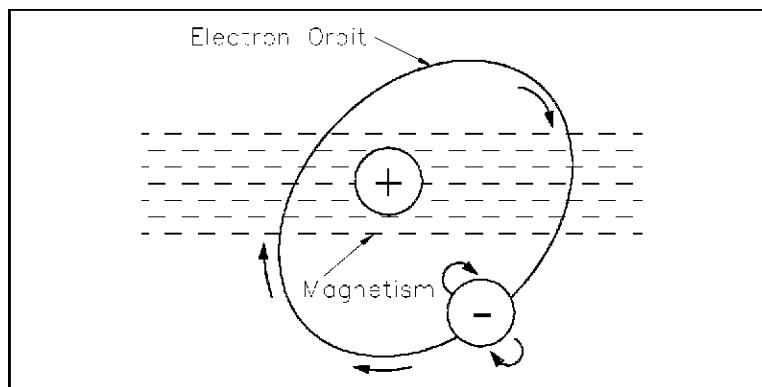

Figure 18 Electron Spinning Around Nucleus Produces Magnetic Field

In magnetic materials, the atoms have certain areas called domains. These domains are aligned such that their electrons tend to spin in the same direction (Figure 19).

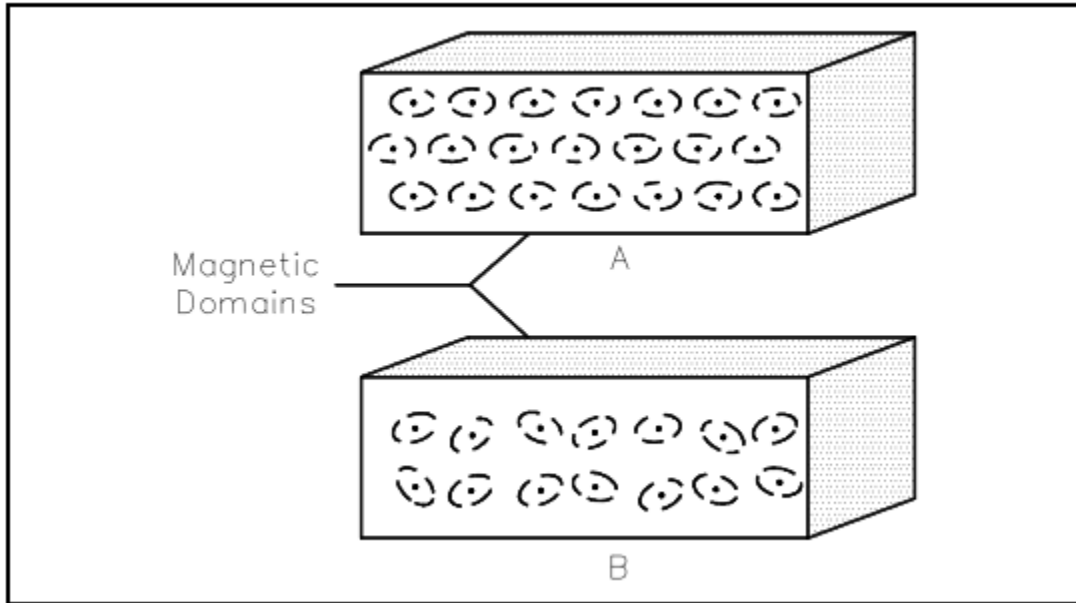

Figure 19 Magnetic Domains

The alignment of these domains results in the formation of magnetic poles at each end of the magnet. These poles are called the north pole and the south pole. The law of magnetism states that like magnetic poles repel and unlike magnetic poles attract one another (Figure 20).

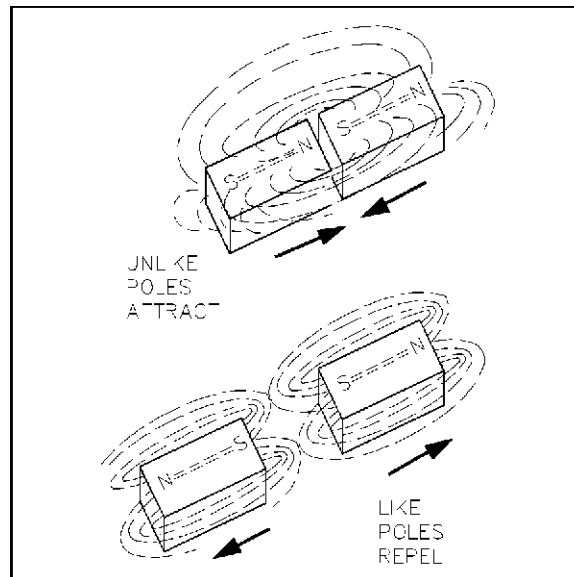

Figure 20 The Law of Magnetic Attraction and Repulsion

### Magnetic Flux

The group of magnetic field lines emitted outward from the north pole of a magnet is called *magnetic flux*. The symbol for magnetic flux is  $\Phi$  (phi).

The SI unit of magnetic flux is the weber (Wb). One *weber* is equal to  $1 \times 10^8$  magnetic field lines.

Example: If a magnetic flux ( $\Phi$ ) has 5,000 lines, find the number of webers.

$$\Phi = \frac{5000 \text{ lines}}{1 \times 10^8 \text{ lines/Wb}} = \frac{5 \times 10^3}{10^8} = 50 \times 10^{-6} \text{ Wb} = 50 \mu\text{Wb}$$

### Magnetic Flux Density

*Magnetic flux density* is the amount of magnetic flux per unit area of a section, perpendicular to the direction of flux. Equation (1-11) is the mathematical representation of magnetic flux density.

$$B = \Phi / A \tag{1-11}$$

where

- B = magnetic flux density in teslas (T)
- $\Phi$  = magnetic flux in webers (Wb)
- A = area in square meters ( $\text{m}^2$ )

The result is that the SI unit for flux density is webers per square meter ( $\text{Wb} / \text{m}^2$ ) One weber per square meter equals one tesla.

Example: Find the flux density in teslas, when the flux is  $800 \mu\text{Wb}$  and the area is  $0.004 \text{ m}^2$ .

Given:  $\Phi = 800 \mu\text{Wb} = 8 \times 10^{-4} \text{ Wb}$

$A = 0.0004 \text{ m}^2 = 4 \times 10^{-4} \text{ m}^2$

$B = \Phi / A = (8 \times 10^{-4} \text{ Wb}) / (4 \times 10^{-4} \text{ m}^2) = 2 \text{ Wb} / \text{m}^2$

### Magnetic Materials

*Magnetic materials* are those materials that can be either attracted or repelled by a magnet and can be magnetized themselves. The most commonly used magnetic materials are iron and steel. A permanent magnet is made of a very hard magnetic material, such as cobalt steel, that retains its magnetism for long periods of time when



the magnetizing field is removed. A temporary magnet is a material that will not retain its magnetism when the field is removed.

*Permeability* ( $\mu$ ) refers to the ability of a material to concentrate magnetic lines of flux. Those materials that can be easily magnetized are considered to have a high permeability. Relative permeability is the ratio of the permeability of a material to the permeability of a vacuum ( $\mu_0$ ). The symbol for relative permeability is  $\mu_R$  ( $\mu$ ).

$$\mu_R = \mu / \mu_0 \quad \text{where } \mu_0 = 4 \pi \times 10^{-7} \text{ H/m} \quad (1-12)$$

Magnetic materials are classified as either magnetic or nonmagnetic based on the highly magnetic properties of iron. Because even weak magnetic materials may serve a useful purpose in some applications, classification includes the three groups described below.

*Ferromagnetic Materials:* Some of the ferromagnetic materials used are iron, steel, nickel, cobalt, and the commercial alloys, alnico and peralloy. Ferrites are nonmagnetic, but have the ferromagnetic properties of iron. Ferrites are made of ceramic material and have relative permeabilities that range from 50 to 200. They are commonly used in the coils for RF (radio frequency) transformers.

*Paramagnetic Materials:* These are materials such as aluminum, platinum, manganese, and chromium. These materials have a relative permeability of slightly more than one.

*Diamagnetic Materials:* These are materials such as bismuth, antimony, copper, zinc, mercury, gold, and silver. These materials have a relative permeability of less than one.

## Electromagnetism

The relationship between magnetism and electrical current was discovered by a Danish scientist named Oersted in 1819. He found that if an electric current was caused to flow through a conductor, the conductor produced a magnetic field around that conductor (Figure 21).

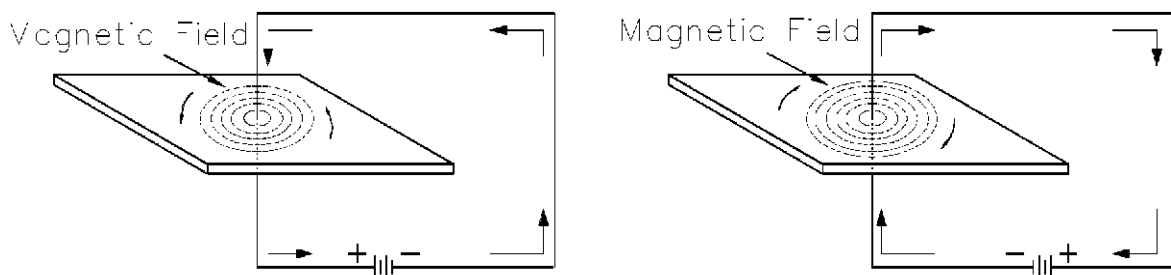

Figure 21 The Magnetic Field Produced by Current in a Conductor

### **Polarity of a Single Conductor**

A convenient way to determine the relationship between the current flow through a conductor and the direction of the magnetic lines of force around the conductor is the left-hand rule for current carrying conductors, as illustrated in Figure 22. The student should verify that the left-hand rule holds true for the examples shown in Figure 21.

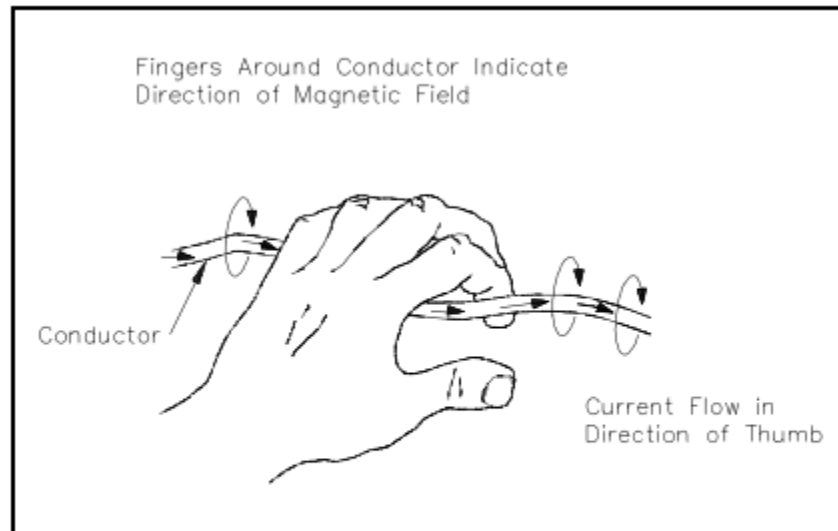

Figure 22 Left-hand Rule for Current Carrying Conductors

### **Magnetic Field and Polarity of a Coil**

Bending a straight conductor into a loop has two results: (1) magnetic field lines become more dense inside the loop, and (2) all lines inside the loop are aiding in the same direction.

When a conductor is shaped into several loops, it is considered to be a coil. To determine the polarity of a coil, use the left-hand rule for coils (Figure 23).

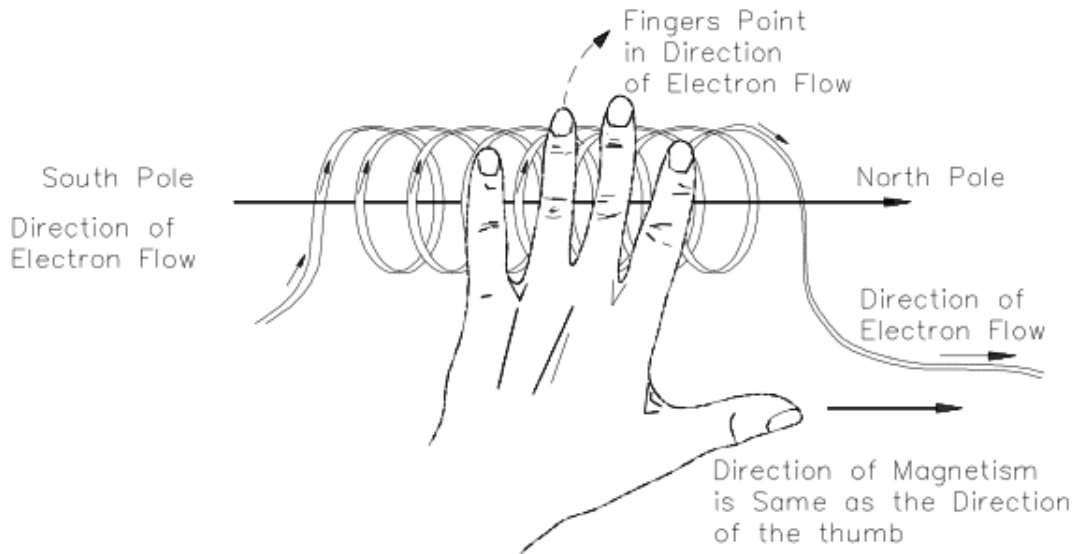

Figure 23 Left-hand Rule for Coils

Adding an iron core inside of a coil will increase the flux density. The polarity of the iron core will be the same as that of the coil. Current flow is from the negative side of the voltage source, through the coil, and back to the positive side of the source (Figure 24).

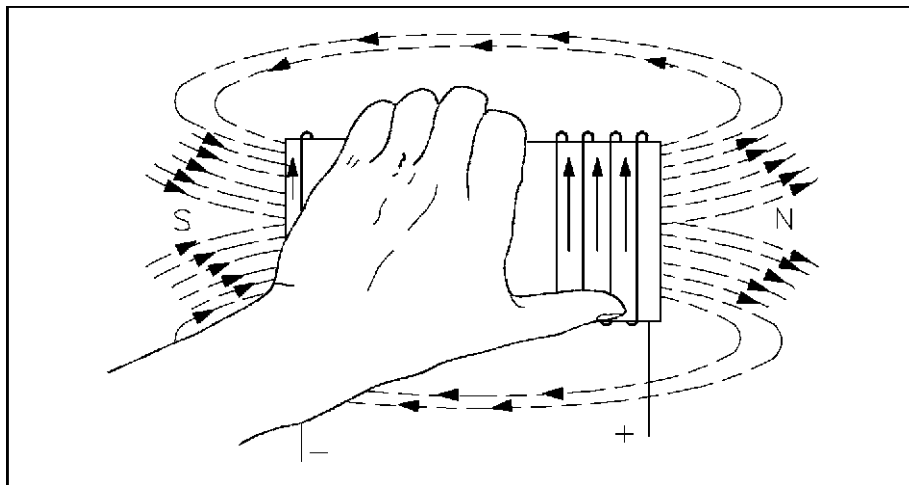

Figure 24 Left-hand Rule to Find North Pole of an Electromagnet

### **Magnetomotive Force**

*Magnetomotive force* (mmf) is the strength of a magnetic field in a coil of wire. This is dependent on how much current flows in the turns of coil: the more current, the stronger the magnetic field; the more turns of wire, the more concentrated the lines of force. The current times the number of turns of the coil is expressed in units called "ampere-turns" (At), also known as mmf. Equation (1-13) is the mathematical representation for ampere-turns (At).

$$F_m = \text{ampere-turns} = N I \quad (1-13)$$

where

$F_m$  = magnetomotive force (mmf)

$N$  = number of turns

$I$  = current

Example: Calculate the ampere-turns for a coil with 1000 turns and a 5 mA current.

$N = 1000$  turns and  $I = 5 \text{ mA}$

substitute

$N = 1000$  turns and  $I = 5 \times 10^{-3}$

$N I = 1000 (5 \times 10^{-3}) = 5 \text{ At}$

### Field Intensity

When a coil with a certain number of ampere-turns is stretched to twice its length, the magnetic *field intensity*, or the concentration of its magnetic lines of force, will be half as great. Therefore, field intensity depends on the length of the coil. Equation (1-14) is the mathematical representation for field intensity, which is related to magnetomotive force as shown.

$$H = F_m / L = N I / L \quad (1-14)$$

where

$H$  = field intensity (At / m)

$N I$  = ampere-turns (At)

$L$  = length between poles of coil (m)

$F_m$  = Magnetomotive force (mmf)

Example 1: Find field intensity of an 80 turn, 20cm coil, with 6A of current.

Solution:

$N = 80$ ,  $I = 6\text{A}$ , and  $N I = 480\text{At}$

$H = 480\text{At} / 0.2\text{m} = 2400 \text{ At/m}$

Example 2: If the same coil in Example 1 were to be stretched to 40 cm with wire length and current remaining the same, find the new value of field intensity.

Solution:

$$N = 80, I = 6A, \text{ and } NI = 480At$$

$$H = 480At / 0.4m = 1200 \text{ At/m}$$

Example 3: The 20 cm coil used in Example 1 with the same current is now wound around an iron core 40 cm in length. Find the field intensity.

Solution:

$$N = 80, I = 6A, \text{ and } NI = 480 \text{ At}$$

$$H = 480At / 0.4m = 1200 \text{ At/m}$$

Note that field intensity for Examples 2 and 3 is the same.

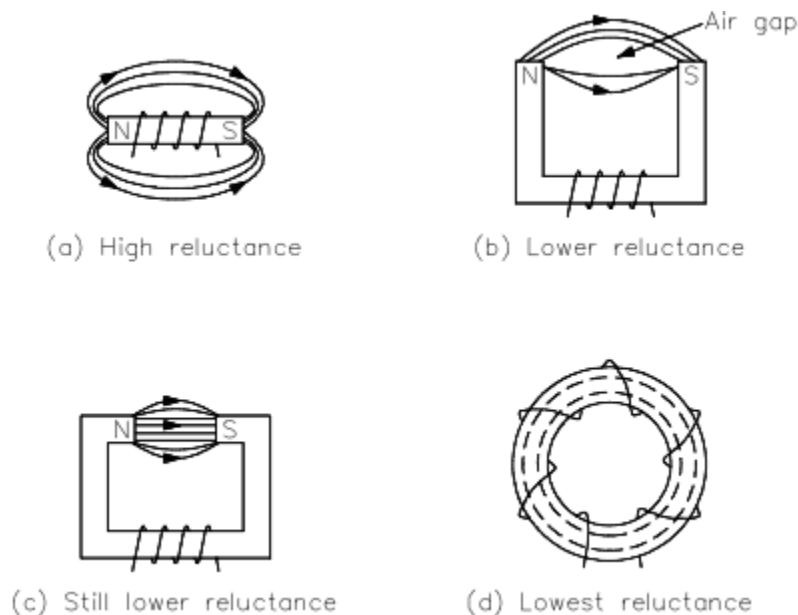

Figure 25 Different Physical Forms of Electromagnets

## Reluctance

Opposition to the production of flux in a material is called *reluctance*, which corresponds to resistance. The symbol for reluctance is  $R$ , and it has the units of ampere-turns per weber (At/Wb).

Reluctance is related to magnetomotive force (mmf) and flux ( $\Phi$ ) by the relationship shown in equation (1-15).

$$R = \text{mmf} / \Phi \quad (1-15)$$

Reluctance is inversely proportional to permeability ( $\mu$ ). Iron cores have high permeability and, therefore, low reluctance. Air has a low permeability and, therefore, a high reluctance.

Generally, different types of materials have different values of reluctance (Figure 25). Air gap is the air space between two poles of a magnet. Since air has a very high reluctance, the size of the air gap affects the value of reluctance: the shorter the air gap, the stronger the field in the gap. Air is nonmagnetic and will not concentrate magnetic lines. The larger air gap only provides space for the magnetic lines to spread out.

### **Summary**

The important information contained in this chapter is summarized below.

#### **Magnetism Summary**

- Magnetic flux - group of magnetic field lines that are emitted outward from the north pole of a magnet
- Magnetic flux density - amount of magnetic flux per unit area of a section, perpendicular to the direction of the flux
- Weber - measure of magnetic flux
- Permeability - ability of a material to concentrate magnetic lines of flux
- Ferromagnetic materials - iron, steel, nickel, cobalt, and commercial alloys with relative permeability ranging from 50-200
- Paramagnetic materials - aluminum, platinum, manganese, and chromium with relative permeability of slightly more than one
- Diamagnetic materials - bismuth, antimony, copper, zinc, mercury, gold, and silver with relative permeability of less than one
- Magnetomotive force (mmf) - strength of a magnetic field in a coil of wire dependent on current flowing through coil
- Ampere turns - current flowing through a coil times the number of turns in the coil
- Field intensity - identifies the magnetic flux density per unit length of a coil
- Reluctance - opposition to the production of flux in a material

## MAGNETIC CIRCUITS

*What is a magnetic circuit? To better understand magnetic circuits, a basic understanding of the physical qualities of magnetic circuits will be necessary.*

- EO 1.8      **EXPLAIN** the physical qualities of a simple magnetic circuit, including relationships of qualities and units of measurements.
- EO 1.9      Given the physical qualities of a simple magnetic circuit, **CALCULATE** the unknown values.
- EO 1.10     **DESCRIBE** the shape and components of a BH magnetization curve.
- EO 1.11     **EXPLAIN** the cause of hysteresis losses.
- EO 1.12     Given Faraday's Law of induced voltage:  
a. **DESCRIBE** how varying parameters affect induced voltage.  
b. **CALCULATE** voltage induced in a conductor moving through a magnetic field.
- EO 1.13     **STATE** Lenz's Law of induction.

### Magnetic Circuits

A magnetic circuit can be compared with an electric current in which EMF, or voltage, produces a current flow. The ampere-turns ( $NI$ ), or the magnetomotive force ( $F_m$  or mmf), will produce a magnetic flux  $\Phi$  (Figure 26). The mmf can be compared with EMF, and the flux ( $\Phi$ ) can be compared to current. Equation (1-16) is the mathematical representation of magnetomotive force derived using Ohm's Law,  $I = E / R$ .

$$\Phi = F_m / R = \text{mmf} / R \quad (1-16)$$

where

- $\Phi$       =      magnetic flux, Wb  
 $F_m$      =      magnetomotive force (mmf), At  
 $R$       =      reluctance, At / Wb

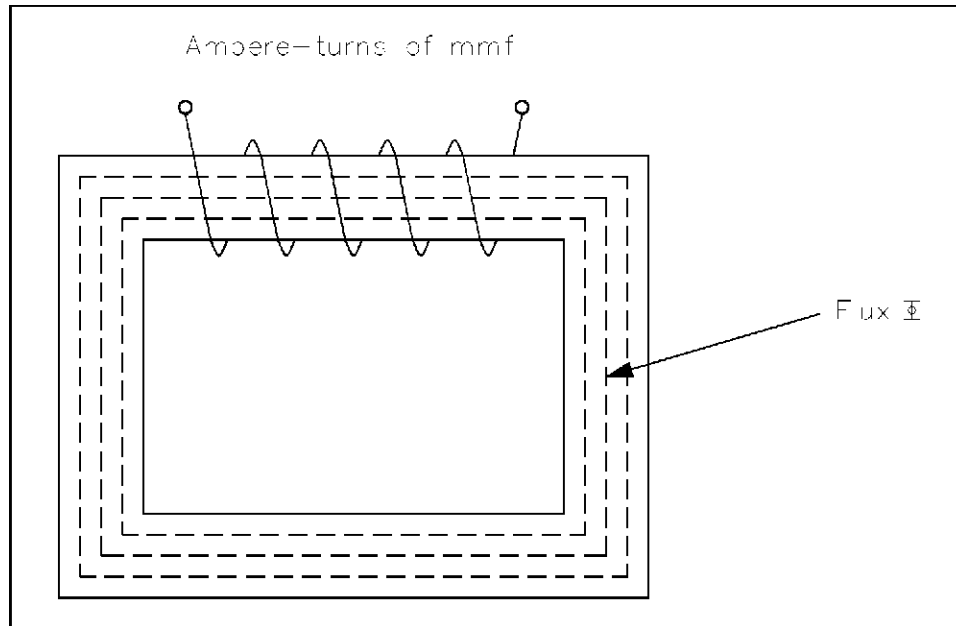

Figure 26 Magnetic Current with Closed Iron Path

Equation (1-17) is the mathematical representation for reluctance.

$$R = L / \mu A \quad (1-17)$$

where

- R = reluctance, At / Wb
- L = length of coil, m
- $\mu$  = permeability of magnetic material, (T-m) / At
- A = cross-sectional area of coil, m<sup>2</sup>

Example: A coil has an mmf of 600 At, and a reluctance of  $3 \times 10^6$  At/Wb. Find the total flux  $\Phi$ .

Solution:

$$\Phi = \text{mmf} / R$$

$$\Phi = 600\text{At} / 3 \times 10^6 = 200 \times 10^{-6} = 200 \mu\text{Wb}$$

### **BH Magnetization Curve**

The BH Magnetization Curve (Figure 27) shows how much flux density (B) results from increasing the flux intensity (H). The curves in Figure 27 are for two types of soft iron cores plotted for typical values. The curve for soft iron 1 shows that flux density B increases rapidly with an increase in flux intensity H, before the core saturates, or



develops a "knee." Thereafter, an increase in flux intensity H has little or no effect on flux density B. Soft iron 2 needs a much larger increase in flux intensity H before it reaches its saturation level at H = 5000 At/m, B = 0.3 T.

Air, which is nonmagnetic, has a very low BH profile, as shown in Figure 27.

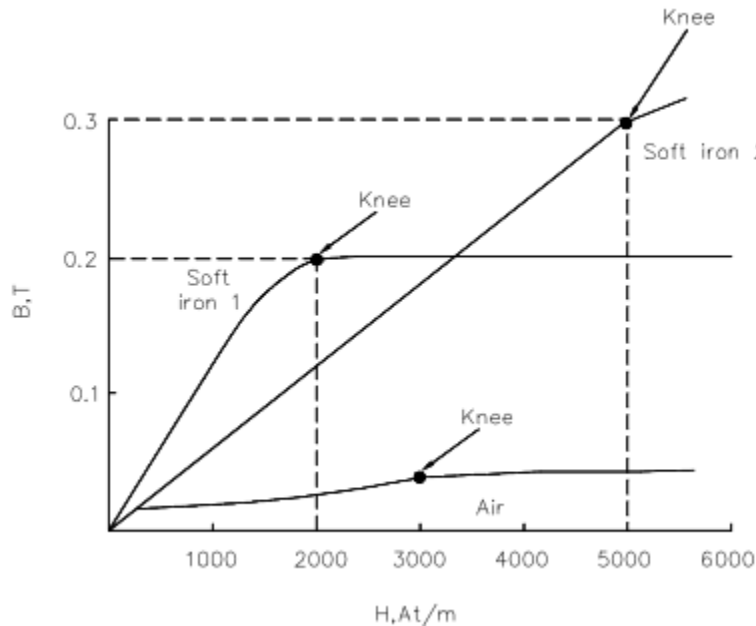

Figure 27 Typical BH Curve for Two Types of Soft Iron

The permeability ( $\mu$ ) of a magnetic material is the ratio of B to H. Equation (1-18) is the mathematical representation for magnetic material permeability.

$$\mu = B / H \tag{1-18}$$

The average value of permeability is measured where the saturation point, or knee, is first established. Figure 27 shows that the normal or average permeability for the two irons as follows.

$$\mu_1 = B / H = 0.2 / 2000 = 1 \times 10^{-4} \text{ T-m/At}$$

$$\mu_2 = B / H = 0.3 / 5000 = 6 \times 10^{-5} \text{ T-m/At}$$

In SI units, the permeability of a vacuum is  $\mu_0 = 4 \pi \times 10^{-7} \text{ H/m}$  or  $1.26 \times 10^{-6} \text{ T-m/At}$ . In order to calculate permeability, the value of relative permeability  $\mu_r$  must be multiplied by  $\mu_0$ . Equation (1-18) is the mathematical representation for permeability.

$$\mu = \mu_r \times \mu_0 \tag{1-19}$$

Example: Find the permeability of a material that has a relative permeability of 100.

$$\mu = \mu_r \times \mu_0 = 100 (1.26 \times 10^{-6})$$

$$\mu = 126 \times 10^{-6} = 1.26 \times 10^{-4} \text{ T-m/At}$$

## Hysteresis

When current in a coil reverses direction thousands of times per second, hysteresis can cause considerable loss of energy. *Hysteresis* is defined as "a lagging behind." The magnetic flux in an iron core lags behind the magnetizing force.

The hysteresis loop is a series of curves that shows the characteristics of a magnetic material (Figure 28). Opposite directions of current will result in opposite directions of flux intensity shown as  $+H$  and  $-H$ . Opposite polarities are also shown for flux density as  $+B$  or  $-B$ . Current starts at the center (zero) when unmagnetized. Positive  $H$  values increase  $B$  to the saturation point, or  $+B_{max}$ , as shown by the dashed line. Then  $H$  decreases to zero, but  $B$  drops to the value of  $B_r$  due to hysteresis. By reversing the original current,  $H$  now becomes negative.  $B$  drops to zero and continues on to  $-B_{max}$ . As the  $-H$  values decrease (less negative),  $B$  is reduced to  $-B_r$  when  $H$  is zero. With a positive swing of current,  $H$  once again becomes positive, producing saturation at  $+B_{max}$ . The hysteresis loop is completed. The loop does not return to zero because of hysteresis.

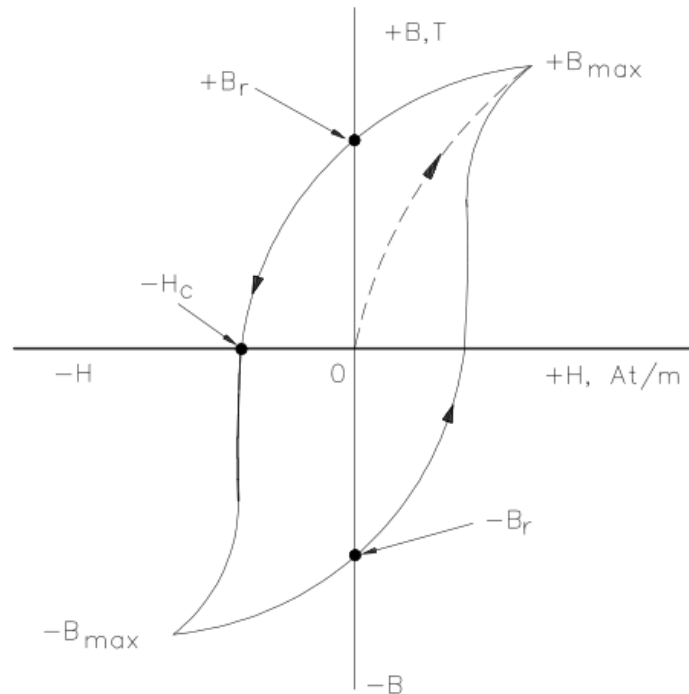

Figure 28 Hysteresis Loop for Magnetic Materials

The value of  $+B_r$  or  $-B_r$ , which is the flux density remaining after the magnetizing force is zero, is called the *retentivity* of that magnetic material. The value of  $-H_c$ , which is the force that must be applied in the reverse direction to reduce flux density to zero, is called the *coercive force* of the material.

The greater the area inside the hysteresis loop, the larger the hysteresis losses.

## Magnetic Induction

Electromagnetic induction was discovered by Michael Faraday in 1831. Faraday found that if a conductor "cuts across" lines of magnetic force, or if magnetic lines of force cut across a conductor, a voltage, or EMF, is induced into the conductor. Consider a magnet with its lines of force from the North Pole to the South Pole (Figure 29). A conductor  $C$ , which can be moved between the poles of the magnet, is connected to a

galvanometer G, which can detect the presence of voltage, or EMF. When the conductor is not moving, zero EMF is indicated by the galvanometer.

If the conductor is moving outside the magnetic field at position 1, zero EMF is still indicated by the galvanometer. When the conductor is moved to position 2, the lines of magnetic force will be cut by the conductor, and the galvanometer will deflect to point A. Moving the conductor to position 3 will cause the galvanometer to return to zero. By reversing the direction in which the conductor is moved (3 to 1), the same results are noticed, but of opposite polarity. If we hold the conductor stationary in the magnetic lines of force, at position 2, the galvanometer indicates zero. This fact shows that there must be relative motion between the conductor and the magnetic lines of force in order to induce an EMF.

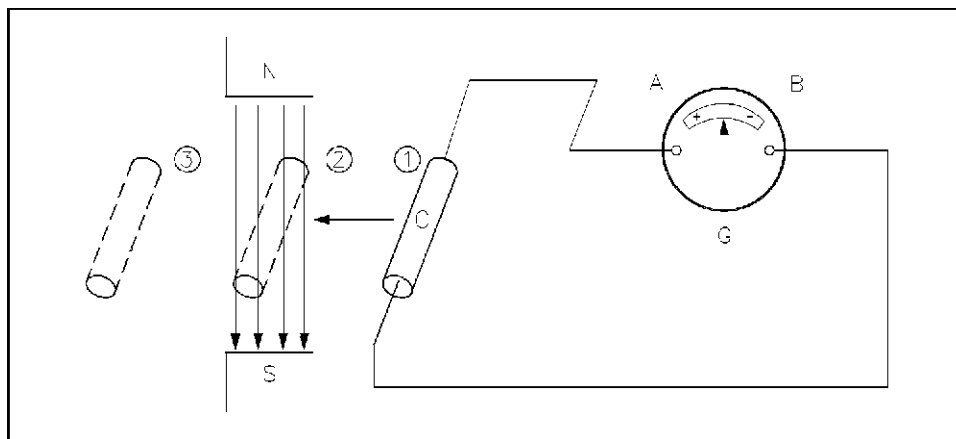

Figure 29 Induced EMF

The most important application of relative motion is seen in electric generators. In a DC generator, electromagnets are arranged in a cylindrical housing. Conductors, in the form of coils, are rotated on a core such that the coils continually cut the magnetic lines of force. The result is a voltage induced in each of the conductors. These conductors are connected in series, and the induced voltages are added together to produce the generator's output voltage.

### **Faraday's Law of Induced Voltage**

The magnitude of the induced voltage depends on two factors: (1) the number of turns of a coil, and (2) how fast the conductor cuts across the magnetic lines of force, or flux. Equation (1-20) is the mathematical representation for Faraday's Law of Induced Voltage.

$$V_{\text{ind}} = -N (\Delta\Phi / \Delta t) \quad (1-20)$$

where

$$V_{\text{ind}} = \text{induced voltage, V}$$

$$\begin{aligned} N &= \text{number of turns in a coil} \\ \Delta\Phi / \Delta t &= \text{rate at which the flux cuts across the conductor, Wb / s} \end{aligned}$$

Example 1: Given: Flux = 4 Wb. The flux increases uniformly to 8 Wb in a period of 2 seconds. Find induced voltage in a coil that has 12 turns, if the coil is stationary in the magnetic field.

Solution:

$$\begin{aligned} V_{\text{ind}} &= -N (\Delta\Phi / \Delta t) \\ \Delta\Phi &= 8\text{Wb} - 4\text{Wb} = 4\text{Wb} \\ \Delta t &= 2\text{s} \end{aligned}$$

then

$$\begin{aligned} \Delta\Phi / \Delta t &= 4\text{Wb} / 2\text{s} = 2\text{Wb/s} \\ V_{\text{ind}} &= -12 (2) = -24\text{V} \end{aligned}$$

Example 2: In Example 1, what is the induced voltage, if the flux remains 4Wb after 2s?

Solution:

$$V_{\text{ind}} = -12 (0/2) = 0\text{V}$$

No voltage is induced in Example 2. This confirms the principle that relative motion must exist between the conductor and the flux in order to induce a voltage.

### **Lenz's Law**

Lenz's Law determines the polarity of the induced voltage. Induced voltage has a polarity that will oppose the change causing the induction. When current flows due to the induced voltage, a magnetic field is set up around that conductor so that the conductor's magnetic field reacts with the external magnetic field. This produces the induced voltage to oppose the change in the external magnetic field. The negative sign in equation (1-20) is an indication that the emf is in such a direction as to produce a current whose flux, if added to the original flux, would reduce the magnitude of the emf.

## Summary

The important information contained in this chapter is summarized below.

### **Magnetic Circuits Summary**

- Simple magnetic circuit magnetic flux ( $\Phi$ ) is proportional to the magnetomotive force ( $F_m$ ) and indirectly proportional to the reluctance ( $R$ ) in a circuit.

$$\Phi \text{ Wb} = F_m \text{ At} / R \text{ At/Wb}$$

- A BH magnetization curve shows how much magnetic flux density ( $B$ ) results from increasing magnetic flux intensity. The "knee" identifies the point where increasing flux intensity ( $H$ ) results in a minimal increase in flux density ( $B$ ).
- Hysteresis losses are caused by reversing current direction thousands of times in a coil.
- Faraday's Law of Induced Voltage depends on the number of turns of a coil and how fast the conductor cuts across the magnetic lines of force or flux.

$$V_{\text{ind}} = -N \Delta\Phi / \Delta t$$

- Lenz's Law states that an induced voltage will have a polarity that will oppose the magnetic field that caused the induced voltage.

## ELECTRICAL SYMBOLS

*To read and interpret electrical system diagrams and schematics, one must be thoroughly familiar with the many symbols used. Once these symbols are mastered, most electrical diagrams and schematics will be understood with relative ease.*

EO 1.14 Given a standard electrical symbol, **IDENTIFY** the component that the symbol represents. The symbols will be for the following components

- |                       |                            |
|-----------------------|----------------------------|
| a. Resistor           | m. Fuse                    |
| b. Capacitor          | n. Junction                |
| c. Inductor           | o. AC voltage source       |
| d. Relay              | P. Voltmeter               |
| e. Contacts           | cl. Ammeter                |
| f. Breaker            | r. Wattmeter               |
| g. Switch             | s. Relay operated contacts |
| h. Transistor         | t. Potential transformer   |
| i. Rheostat           | u. Current transformer     |
| J. Diode              | v. Wye (Y) connection      |
| k. Ground connections | w. Delta (A) connection    |
| l. Vacuum tube        | x. Light bulb              |
|                       | y. Battery                 |

### Symbols

The symbols for the various electrical components that will appear on electrical diagrams and schematics are shown in Figure 30.

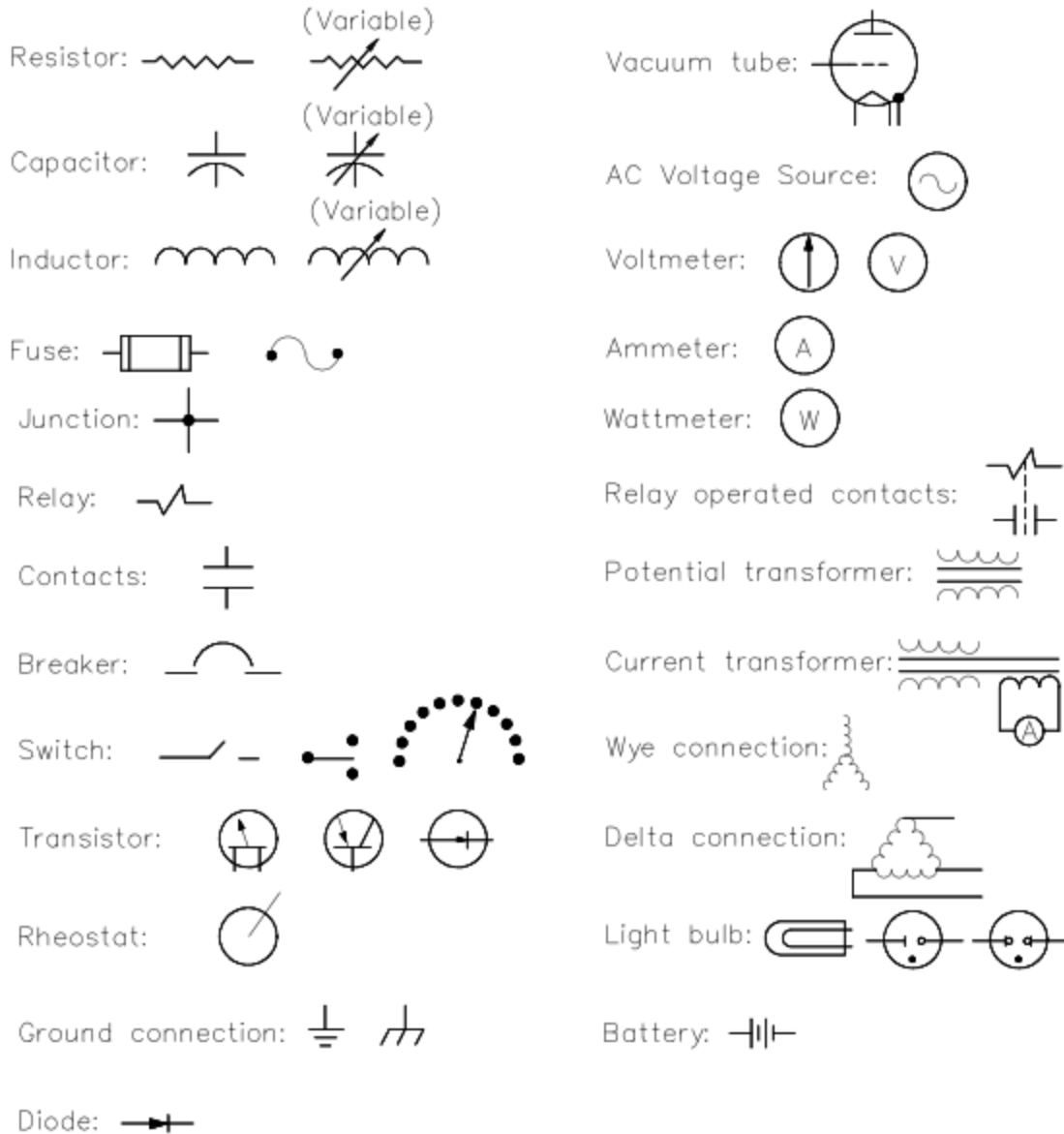

Figure 30 Electrical Symbols

### Summary

The important information contained in this chapter is summarized below.

**Electrical Symbols Summary**

- To read and interpret electrical system diagrams and schematics, one must be thoroughly familiar with the many symbols used. Once these symbols are mastered, most electrical diagrams and schematics will be understood with relative ease.

## Appendix A: Metric System and Powers of Ten

### Metric System

Units of the international metric system, commonly called SI (system internationale), are used in electricity. The seven basic units are shown on Table A-1. Two supplementary units of SI are shown on Table A-2.

**TABLE A-1**

#### **BASE UNITS of the INTERNATIONAL METRIC SYSTEM**

<u>Quantity</u>	<u>Base Unit</u>	<u>Symbol</u>
Length	meter	m
Mass	kilogram	Kg
Time	second	s
Electric current	ampere	A
Thermodynamic temperature	Kelvin	K
Light intensity	Candela	cd
Amount of substance	mole	mol

**TABLE A-2**

#### **SUPPLEMENTARY SI UNITS**

<u>Quantity</u>	<u>Unit</u>	<u>Symbol</u>
Plane angle	radian	rad
Solid angle	steradian	Sr

These base and supplemental units are used to derive other units. Most of the units of measure used in electricity are derived units. These units are shown on Table A-3. Some of these are derived from the base units, and some are derived from other derived units, or a combination of both. For example, the unit of current is the ampere, which is derived from the base units of second and coulomb. The derivation of these units is beyond the scope of this text. However, units commonly used in the study and use of electricity and their relationship to other units of measure are discussed in Chapter 3, *Units of Electrical Measurement*.



**TABLE A-3**  
**DERIVED SI UNITS**

<u>Quantity</u>	<u>Derived Unit</u>	<u>Symbol</u>
Energy	joule	J
Force	newton	N
Power	watt	W
Electric charge	coulomb	C
Electric potential	volt	V
Electric resistance	ohm	$\Omega$
Electric conductance	mho	$\text{\textcircled{O}}$
Electric capacitance	farad	F
Electric inductance	henry	H
Frequency	hertz	Hz
Magnetic flux	weber	Wb
Magnetic flux density	tesla	T

### **Metric Prefixes**

When working with basic electrical measurement units, sometimes the values are too large or too small to express conveniently. For convenience, add metric prefixes (Table A-4) to the basic unit. For example, if we have a resistor that is 1,000,000 ohms ( $\Omega$ ), we can add the prefix kilo, or its designated symbol K, and express the value as 1,000 K $\Omega$ , or the metric prefix mega (symbol M) and express the value as 1 M $\Omega$ . In the case of capacitance or current, we may have a very small value such as 0.002 amperes (symbol A) or 0.000005 farads (symbol F). These values can be expressed by adding the prefix milli (symbol m) and expressing the current as 2 milli amperes or 2 mA, or adding the prefix micro (symbol  $\mu$ ) and expressing the capacitance as 5 micro farads, or 5  $\mu$ F.

To use the prefixes listed in Table A-4, divide the value of the unit by the value of the prefix, and then add the prefix to the unit.

**TABLE A-4**  
**METRIC PREFIXES USED in ELECTRICITY**

<u>Prefix</u> (letter symbol)	<u>Value</u>	
mega (M)	million	1,000,000
kilo (k)	thousand	1,000
milli (m)	thousandth	0.001
micro ( $\mu$ )	millionth	0.000,001
nano (n)	thousand-millionth	0.000,000,001
pico (p)	million-millionth	0.000,000,000,001

**Powers of Ten**

Another way to express large and small values is to convert the value to powers of 10. This is a convenient way to express values and keep the units in the basic unit notation, rather than converting from one unit of measure to another unit that may be larger or smaller, as we did in metric prefixes above.

Examples of expressing numbers as power of 10 are shown in Table A-5.

**TABLE A-5 - POWERS of 10**

<u>Number = Power of 10</u>	<u>Commonly Read As</u>
0.000,001 = $10^{-6}$	10 to the minus six
0.000,01 = $10^{-5}$	10 to the minus five
0.000,1 = $10^{-4}$	10 to the minus four
0.001 = $10^{-3}$	10 to the minus three
0.01 = $10^{-2}$	10 to the minus two
0.1 = $10^{-1}$	10 to the minus one
1 = $10^0$	10 to the zero
10 = $10^1$	10 to the first
100 = $10^2$	10 to the second
1,000 = $10^3$	10 to the third
10,000 = $10^4$	10 to the fourth
100,000 = $10^5$	10 to the fifth
1,000,000 = $10^6$	10 to the sixth

Rules associated with powers of ten are as follows:

**Rule 1:** To express numbers larger than 1 as a small number times a power of 10, move the decimal point to the left as many places as desired. Then multiply the number obtained by 10 to a power that is equal to the number of places moved.

**Example:** To convert 6,000,000, move the decimal point 6 places to the left (6.000,000), then multiply 6 times 10 raised to a power equal to the number of decimal places moved, obtaining  $6 \times 10^6$ .

$$6,000,000 = 6 \times 10^6$$

**Rule 2:** To express numbers less than 1 as a whole number times a power of 10, move the decimal point to the right as many places as desired. Then multiply the number obtained by 10 to a negative power that is equal to the number of places moved.

**Example:** To convert 0.004A, move the decimal point 3 places to the right (004.), then multiply 4 by 10 raised to a negative power equal to the number of decimal places moved, obtaining  $4 \times 10^{-3}\text{A}$ .

$$0.004\text{A} = 4 \times 10^{-3}\text{A}$$

**Rule 3:** To convert a number expressed as a positive power of 10 to a decimal number, move the decimal point to the right as many places as the value of the exponent.

**Example:** To convert  $1 \times 10^3\Omega$ , move the decimal point 3 places to the right (1000.0), then drop the multiple of power of 10, obtaining 1,000.

$$1 \times 10^3 = 1,000\Omega$$

**Rule 4:** To convert a number expressed as a negative power of 10 to a decimal number, move the decimal point to the left as many places as the value of the exponent.

**Example:** To convert  $5 \times 10^{-3}\text{A}$ , move the decimal point 3 places to the left (0.005), then drop the multiple of the power of 10, obtaining 0.005A.

$$5 \times 10^{-3}\text{A} = 0.005\text{A}$$

**Rule 5:** To multiply 2 or more numbers expressed as powers of 10, multiply the coefficients to obtain the new coefficient, and add the exponents to obtain the new exponent of 10.

**Example:** To multiply  $2 \times 10^5$  by  $3 \times 10^{-3}$ , multiply  $2 \times 3$  to get 6, then add the exponents of the powers of 10,  $5 + (-3)$ , to get an exponent of 2, obtaining a product of  $6 \times 10^2$ .

$$(2 \times 10^5) (3 \times 10^{-3}) = 6 \times 10^2$$

**Rule 6** To divide powers of 10, use the formula:

$$1 / 10^n = 1 \times 10^{-n}$$

We can transfer any power of 10 from numerator to denominator, or vice-versa, simply by changing the sign of the exponent.

**Example:** To divide  $8 \times 10^1$  by  $2 \times 10^{-4}$ , divide the numerical number 8 by 2 = 4, then bring the power of 10, in the denominator, up to the numerator and change the sign of its exponent, then add the exponents together:

$$8 \times 10^{-5} / 2 \times 10^{-4} = 4 \times 10^{-5+4} = 4 \times 10^{-1}$$

Table A-6 shows the metric prefixes expressed as powers of 10.

**Table A-6**

**Metric Prefixes Expressed  
as Powers of 10**

<u>Metric Prefix</u>	<u>Power of 10</u>
mega (M)	$10^6$
kilo (k)	$10^3$
milli (m)	$10^{-3}$
micro ( $\mu$ )	$10^{-6}$
nano (n)	$10^{-9}$
pico (p)	$10^{-12}$

Electrical units can be expressed in different, but equivalent, units by using prefixes expressed in powers of 10.

**Examples:**

Express  $780,000\Omega$  in Megohms (M $\Omega$ ).

$$1\Omega = 10^{-6}\text{M}\Omega$$

$$780,000\Omega = 780,000\Omega \times 10^{-6} = 0.78 \text{ M}\Omega$$

Express 4.5 V in millivolts (mV).

$$1\text{V} = 10^3 \text{ mV}$$

$$4.5\text{V} = 4.5 \times 10^3 \text{mV} = 4500 \text{ mV}$$

Express 0.015 A in milliamperes (mA).

$$1 \text{ A} = 10^3 \text{ mA}$$

$$0.015 \text{ A} = 0.015 \times 10^3 = 15 \text{ mA}$$